

PARTS BREAKDOWN FOR MODELS TR10-SERIES SN#39387  
RICE HYDRO, INC.

PART NUMBER..	DESCRIPTION..	QTY REQ'D
UD04-0007.38	SEAL	1
UD04-0007.43	SEAL	3
UD04-0014.31	PLUNGER ROD	3
UD04-0023.21	SUPPORT RING	3
UD04-0028.29	CRANKSHAFT	1
UD04-0115.08	ROD GUIDE	3
UD04-0208.71	BACK COVER	1
UD04-0209.54	CRANKCASE	1
UD04-0248.03	BEARING	2
UD04-0301.55	SLINGER RING	3
UD04-0303.18	PLUNGER NUT	3
UD04-0501.C6	BEARING CAP	1
UD04-0501.C7	BEARING CAP	1
UD04-0602.75	GASKET	1
UD02-0605.09	GASKET	1
UD02-0605.43	GASKET	1
UD04-0801.17	KEY	1
UD04-1101.A3	O-RING	6
UD04-1101.A2	O-RING	6
UD04-1101.30	RETAINER O-RING	3
UD02-1101.60	O-RING	3
UD04-1101.73	O-RING	2
UD04-1205.31	PLUNGER - 20 MM	3
UD04-1403.05	WASHER	8
UD04-1403.40	ONLY AVAIL IN KIT #40	3
UD02-1411.03	WASHER	8
UD04-1502.14	CONNECTING ROD PIN	3
UD04-1534.03	SHIM .003	1
UD04-1534.04	SHIM .010	1
UD04-1603.A7	DISCHARGE PLUG	1
UD04-1603.A8	INLET PLUG	1
UD04-1603.B8	SIGHT GLASS	1
UD04-1603.94	VALVE CAP	6
UD04-1603.02	DRAIN PLUG	1
UD04-1604.F1	MANIFOLD	1
UD02-1804.25	BOLT	8
UD02-1804.52	BOLT	5
UD04-1804.82	BOLT	8
UD04-6000.52	BRONZE CONNECTING ROD	3
UD04-6058.58	DIP STICK	1

GEAR REDUCTION..

UD04-0004.29	1" DRIVE GEAR	1
UD04-0007.33	SEAL	1
UD04-0213.27	PUMP GEAR	1
UD04-0214.14	BEARING	1
UD04-0228.30	GEAR BOX HOUSING	1
UD04-0516.04	FLANGE	1
UD04-0602.42	GASKET - GEAR BOX HOUSING	1
UD04-0602.59	GASKET - GEAR BOX	1
UD04-0605.43	OIL PLUG GASKET	1
UD04-0614.07	SET SCREW	1
UD04-1411.02	WASHER	4
UD04-1412.04	WASHER	7
UD04-1506.20	SNAP RING	1
UD04-1506.21	SNAP RING	1
UD04-1603.02	DRAIN PLUG	1
UD04-1603.06	OIL SIGHT GLASS	1
UD04-1805.03	BOLT	7
UD04-1805.23	BOLT	4
UD04-6058.26	OIL VENT CAP	1

PARTS BREAKDOWN FOR MODELS TR10-SERIES SN#39387  
RICE HYDRO, INC.

MISCELLANEOUS PARTS..

PART NUMBER..	DESCRIPTION..	QTY REQ'D
GAUGE-6000	0-6000 PSI LIQUID FILLED GAUGE	1
NEEDLEVALVE-1/4	AIR BLEED VALVE	1
BALLVALVE-7250-3/8	OUTLET BALLVALVE	1
UNLOADER-5000PSI	500-5000 PSI PRESSURE REGULATOR	1
CARTON-TR6	EXTRA LARGE SHIPPING BOX	1
LINESTRAINER-1/2	INLINE STRAINER	1
HOSESWIVEL-1/2	SWIVEL HOSE INLET	1
PUMP-4.5/5000PSI	TRIPLEX PLUNGER PUMP - <i>GAS ENGINES</i>	1
PUMP-4.5/5000/SHAFT	TRIPLEX PLUNGER PUMP - <i>ELECTRIC MOTORS</i>	1
MOTOR-TRE10	15HP 3PH 60HZ 208/230/460V MOTOR	1
MOTOR-TRE10F	15HP 3PH 50HZ 220/380/440V MOTOR	1
HONDA-GX630RHQZB3	GAS ENGINE	1
HONDA-HD654270	MUFFLER FOR ENGINE	1
BATTERY-ACCESSORIES	BATTERY AND ACCESSORIES	1
LABEL-KIT-TR	INSTRUCTION AND CAUTION STICKERS	1

OUTLET HOSE..

HOSE-3/8-5000X8-RH	8' FOOT OUTLET HOSE - STANDARD	1
COUPLERPLUG-S-3/8	MALE PUMP OUTLET - PIPING	1
COUPLERBODY-S-3/8	FEMALE PUMP OUTLET - HOSE	1
HOSE-HYD-3/8-HP	SPECIFY LENGTH OF HOSE	
FITTING-3/8-MPIPE	FITTING FOR HOSE - RIGID	1
FITTING-3/8-MPX	FITTING FOR HOSE - SWIVEL	1

KITS..

\*Kits are all inclusive

UD04-KIT-UD9	SEAL KIT
UD04-KIT-UD40	PLUNGER O-RING KIT
UD04-KIT-UD42	BRASS KIT
UD04-KIT-UD63	VALVE KIT

# GKC 17/36-S

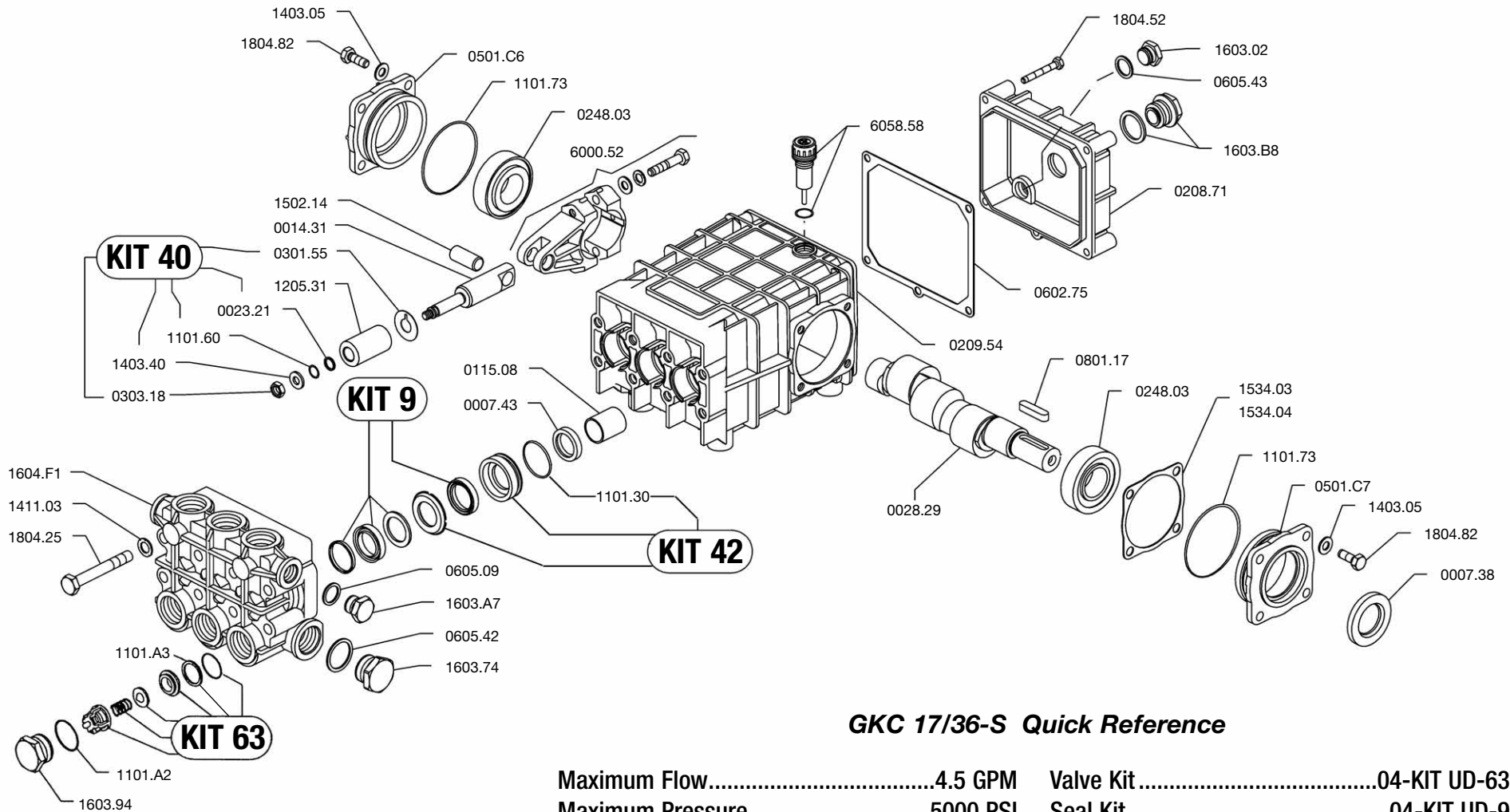

## GKC 17/36-S Quick Reference

Maximum Flow.....	4.5 GPM	Valve Kit.....	04-KIT UD-63
Maximum Pressure .....	5000 PSI	Seal Kit.....	04-KIT UD-9
Rated Pump Speed .....	1450 RPM	Brass Kit.....	04-KIT UD-42
Oil Capacity .....	40 oz. UDOR LUBE	Plunger Bolt Kit.....	04-KIT UD-40
	or SAE 30W	Plunger Part # .....	04-1205.31
	Non-Detergent Oil	Plunger Diameter .....	20 MM

Revised 11-1-2006

# 5038.C2 & 5042.C2

10 oz. 90 wt. Gear Lube

