



DAKE VDL-18

INSTRUCTIONAL MANUAL



Shown with optional wheel set

⚠ WARNING! Read and understand all instructions and responsibilities before operating. Failure to follow safety instructions and labels could result in serious injury.



Table of Contents

DAKE Standard Limited Warranty	3
Return & Refund Policy	5
Specifications	6
Safety Warnings	8
Safety Labels:.....	10
Adjustments	11
General Instructions:	11
Blade Installation Steps:	11
High to Low Setting & FPM setting:.....	12
Blade Speed Chart	13
Blade Guidepost Adjustment:	13
Table Tilt:.....	14
Fence Assembly Adjustment:	14
Top Idler Wheel Camber Adjustment	14
Maintenance	15
Trouble Shooting:	16
Parts List	17
Upper Wheel Assembly: (Parts List Below)	17
Table and Fence Assembly: (Parts List Below)	20
Upper & Lower Blade Guides Assembly: (Parts List Below).....	23
Lower Wheel & Motor Assembly: (Parts List Below)	25
Order Information	29
VDL-18 Wiring Diagram:.....	30



DAKE Standard Limited Warranty

Finished Machines

Dake warrants to the original purchaser the finished machine manufactured or distributed by it to be free from defects in material and workmanship under normal use and service within 1 year (12 months) from the delivery date to the end user.

Parts

Dake warrants to the original purchaser the component part manufactured or distributed by it to be free from defects in material and workmanship under normal use and service within 30 days from the delivery date to the end user.

The standard limited warranty includes the replacement of the defective component part at no cost to the end user.

Sale of Service (Repairs)

Dake warrants to the original purchaser the component part repaired by Dake Corporation at the manufacturing facility to be free from defects in material and workmanship under normal use and service within 90 days from the return date to the end user, as it pertains to the repair work completed. The standard limited warranty includes repair of the defective component part, at no cost to the end user.

Warranty Process

Subject to the conditions hereinafter set forth, the manufacturer will repair or replace any portion of the product that proves defective in materials or workmanship. The manufacturer retains the sole right and option, after inspection, to determine whether to repair or replace defective equipment, parts or components. The manufacturer will assume ownership of any defective parts replaced under this warranty.

All requested warranty claims must be communicated to the distributor or representative responsible for the sale. Once communication has been initiated, Dake Customer Service must be contacted for approval:

Phone: (800) 937-3253

Email: customerservice@dakecorp.com

When contacting Dake, please have the following information readily available:

- Model #
- Serial #
- Sales Order #

Purchasers who notify Dake within the warranty period will be issued a Case number and/or a Return Material Authorization (RMA) number. If the item is to be returned per Dake's request, the RMA number must be clearly written on the exterior packaging. Any item shipped to Dake without an RMA will not be processed.



Warranty Exceptions:

The following conditions are not applicable to the standard limited warranty:

- (a) Part installation or machine service was not completed by a certified professional, and is not in accordance with applicable local codes, ordinances and good trade practices.
- (b) Defects or malfunctions resulting from improper installation or failure to operate or maintain the unit in accordance with the printed instructions provided.
- (c) Defects or malfunctions resulting from abuse, accident, neglect or damage outside of prepaid freight terms.
- (d) Normal maintenance service or preventative maintenance, and the parts used in connection with such service.
- (e) Units and parts which have been altered or repaired, other than by the manufacturer or as specifically authorized by the manufacturer.
- (f) Alterations made to the machine that were not previously approved by the manufacturer, or that are used for purposes other than the original design of the machine.



Return & Refund Policy

Thank you for purchasing from Dake! If you are not entirely satisfied with your purchase, we are here to help.

Returns

All Dake manufactured / distributed machines, parts and couplings include a 30-day return option. These policies are valid from the date of final shipment to the end user.

To be eligible for a return, the item must be unused and in the same condition as received.

All requested warranty claims must be communicated to the distributor or representative responsible for the sale. Once communication has been initiated, Dake Customer Service must be contacted for approval:

Phone: (800) 937-3253

Email: customerservice@dakecorp.com

Once the return request has been approved by Customer Service, a representative will supply a Return Material Authorization (RMA) number. The returned item must have the provided RMA number clearly marked on the outside packaging. Any item received without an RMA number clearly visible on the packaging will not be processed.

An RMA number can only be provided by the Dake Customer Service team and must be obtained prior to the return shipment.

Refunds

Once the item has been received and inspected for damages, a representative will notify the requestor referencing the provided RMA number.

If the return is approved, a refund will be issued to the original method of payment, less a 20% restocking fee. The restocking fee may be waived if an order is placed at the time of return with like-value merchandise.

Transportation costs are the responsibility of the end user and will not be credited upon return approval.

Any item that is returned after the initial 30 days or has excessive/obvious use will not be considered for a full refund.

Specifications

VDL-18 Bandsaw	
Motor Voltage/HP	115/ 230V (prewired 115V)/ 1-3/4HP
Breaker	15 amp for both 115V and 230V
Throat	18 7/32" (463mm)
Table cast iron	20" x 26" (508mm x 660mm)
Front table to center of blade	11" (280mm)
Table tilt	- 6 degrees + 45 degrees
Miter slot	3/8" x 3/4" (9.525mm x 19.05mm)
Table height	38" (965mm)
Fly wheel	Cast iron
Resaw capacity	16" (406.4mm)
Minimum blade length	143 3/4" (3,651mm)
Maximum blade length	145 1/2" (3,695mm)
Maximum blade width	1-1/4" (31.75mm)
Minimum blade width	1/8" (3mm)
Guides	Laguna ceramic
Blade speeds (FPM)	<u>Variable speeds</u> Low: 100-290 High: 1200-3500
Dust chute diameter (OD)	4" x 2
Height	77 3/4" (1,975mm)
Machine dimensions (W x D) Base footprint	36 3/16" x 36" (919mm x 915mm) 27" x 19 2/3" (688mmx500mm)
Machine dimensions with mobility kit (W x D) Base footprint with mobility kit	43" x 36" (1093mm x 915mm) 37 3/8" x 24 11/32" (949mm x 618mm)
Weight gross	515 lbs (234 kg)
Weight net	480 lbs (218 kg)
Package size (W x D x H)	81 1/2" x 33 7/8" x 30-1/4" (2070mm x 860mm x 770mm)
Variable Foot Brake	Disk Rotor
Mobility kit	Optional
Industrial work-light	Optional



- In the space provided record the serial number and model number of the machine. This information is only found on the black Dake tag. If contacting Dake this information must be provided to assist in identifying the specific machine.

Model No:

Part No:

Serial No:

Date of Purchase:

Safety Warnings

BEFORE USE, ALL SAFETY INSTRUCTIONS MUST BE READ

- As you know, the vertical bandsaw is a universal saw for contour cutting. Blade selection is important and by choosing the right blade, you can make most any pattern cutting on most any material with this machine. However, the most important thing is to realize how to operate it in a safe and correct way and how to maintain it.
- We have tried to supply you all the information about these. Please be sure to look through all the contents in this manual so that you may obtain the maximum efficiency and the longest machine life with minimum expense.
- The specifications and information in this manual were current at the time this manual was approved for printing. Dake, whose policy is one of continuous improvement, reserves the right, however, to change specifications or design at any time without incurring obligations.
- Always include the part number, model number, and parts description, for parts orders or correspondence concerning your bandsaw, so we can supply you a rapidly after-sales service.

▲ WARNING

1. Read the operator's manual carefully. Learn the tools applications and limitations, as well as the specific potential hazards peculiar to it.
2. Always wear approved safety glasses/face shields while using this machine.
3. Make certain the machine is properly grounded.
4. Before operating the machine, remove tie, rings, watches, other jewelry, and roll up sleeves above the elbows. Remove all loose clothing and confine long hair. **DO NOT** wear gloves when operating.
5. Keep the floor around the machine clean and free of scrap material, oil and grease.
6. Always keep machine guards in place when the machine is in use. If removed for maintenance purposes, use extreme caution, and replace the guards immediately.
7. **DO NOT** overreach! Always maintain a balanced stance. **Do not fall or lean against blades or other moving parts.**
8. Use only sharp blades. Dull blades are dangerous.
9. Make all machine adjustments or maintenance with the machine unplugged from the power source.

10. Use the right tool. DO NOT force a tool or attachment to do a job which it was not designed for.
11. DO NOT make cuts requiring more power than is available on the machine.
12. Replace warning labels if they become obscured or removed.
13. Make certain the motor switch is in the OFF position before connecting the machine to power.
14. Give your work undivided attention. Looking around, carrying on a conversation. And “horse-play” is careless acts that can result in serious injury.
15. Make a habit of checking to see that keys and adjusting wrenches are removed before turning on the machine.
16. Keep visitors a safe distance from the work area.
17. Use recommended accessories; improper accessories may be hazardous.
18. Never place hands directly in line with the saw blade.
19. Always use push sticks when cutting small material.
20. Raise or lower the blade guide only when the machine has been turned off and the blade has stopped moving.
21. Read and understand warnings posted on the machine.
22. DO NOT use attachments for any other purpose than for what they were designed for.

Failure to comply with all these warnings could lead to serious injury.



This is the safety alert symbol.

- When you see this symbol on your press be alert to the potential for personal injury.

▲ WARNING

All electrical connections must be done by a qualified electrician. Failure to comply may cause serious injury!

All adjustment or repairs must be done with the machine disconnected from the power source. Failure to comply may result in serious injury!

Safety Labels:

SAFETY INSTRUCTIONS

LOCKOUT PROCEDURE

1. Announce lockout to other employees.
2. Turn power off at main panel.
3. Lockout power in off position.
4. Put key in pocket.
5. Clear machine of all personnel.
6. Test lockout by hitting run button.
7. Block, chain or release stored energy sources.
8. Clear machine of personnel before restarting machine.

Label Part # 84605

⚠ DANGER

High voltage.
Can cause severe injury or death.

Service by authorized personnel only.
Use lockout.



⚠ PELIGRO ⚠

Alta tensión.
Puede provocar lesiones severas o la muerte.

Para reparaciones, emplee personal autorizado solamente.
Use cierre eléctrico.

Label Part # 84395

SAFETY INSTRUCTIONS

1. Read the instruction manual thoroughly before operating this machine.
2. Wear safety glasses.
3. Wear gloves only when handling material or replacing blade.
4. Never wear gloves while blade is rotating.
5. Do not perform cutting operations which exceed machine capacity.
6. Do not force machine to stall blade or breakage might occur.
7. Clamp workpiece securely.
8. Always use stock stands on both sides of saw blade to support material.
9. Use blade with the correct specification for the material being cut.
10. Keep floor around machine clean and free from chips, scraps, oil, and coolant.
11. Turn electrical power off before performing maintenance, servicing, or changing blades.

Label Part # 84605

⚠ WARNING



Never reach into the point of operation.

Do not operate without all guards in place.

Label Part # 82199

Adjustments

General Instructions:

Below are some basic instruction to properly operate the VDL-18 bandsaw machine.

1. Make sure the blade is properly adjusted for tension and tracking.
2. Adjust blade guide assembly so that the guide guides are just above the workpiece (about 3/16") allowing minimum exposure to the blade.
3. If using the fence, move it into position and lock it to the guide rail. If you are using the miter gauge for a crosscut, the fence should be moved safely out of the way.
4. Turn the machine on and wait a few seconds for the machine to fully get up to speed.
5. Place the straightest edge of the workpiece against the fence and push the workpiece slowly into the blade. Do not force the workpiece into the blade. Let the blade do the work.
NOTE: (DO NOT over feed that bandsaw blade. This will reduce blade life and have a greater chance of breaking the blade).
6. When cutting long stock, the operator should use roller stands, support tables, or an assistant to help stabilize the workpiece.
7. When cutting at an angle with a tilted table, provide a guide against which the material being cut can rest. Freehand cutting at an angle can result in injury, and maintaining an accurate cut is difficult.

Blade Installation Steps:



Disconnect the machine from the power source before making any adjustments.

1. Open the top door to the machine. Located on the back side of tensioner wheel is 13mm bolt and a 1/2" nut. Loosen to be finger loose. You **DO NOT** need to take the screw all the way out. This will save you a headache in the future.
2. Lower the tension lever handle down to the minimum position. This will allow the blade to lose its tension.
3. Loosen the blue blade guides located the adjustable blade guide height also below the worktable.
NOTE: (Sometimes, the upper wheel might stick in place over time after the tension handle is compressed. Spray WD-40 or PB-Blaster in the tensioning slot is located occasionally to prevent this from happening. If the wheel is still stuck, pull downward on the wheel to be released)
4. On the top section door, open the red or yellow magnetic blade guard to expose the blade cavity. Finally open the bottom cabinet door to expose the drive pulley of the saw.
5. With the bottom door open, locate the plastic blade guide slider that slide between the bandsaw blade and remove.
6. Remove the throating plate that is surrounding the blade on the worktable.
7. Carefully unravel the blade, and slide he blade into the slot leading to the worktable throat plate area with the blade teeth facing you. Finally slide the blade into the left-hand side grove located on the main frame of the bandsaw.

8. Work the blade around the upper and lower pulley wheels. Make sure the blades are as evenly centered around the wheels as best as you can.
9. Raise the blade tensioner lever handle to the maximum position to tighten the blade.
10. To make your final adjustments, the adjusting wheel that is facing upward above the worktable adjusts your final blade tensioning. The wheel has a reverse thread, therefore turning the wheel to the left will tighten the blade tension and turning the wheel to the right will loosen the blade tension.
11. The scale inside the top half door of the bandsaw is a good reference to use determining what tensions are good based off the width of the blades for many applications.

High to Low Setting & FPM setting:

- First will explain the procedure to change the 18CX from high gear to low gear or vice versa. The same procedure applies both ways.



Disconnect the machine from the power source before making any adjustments.

1. Turn the machine off and unplug from the power source.
NOTE: (The motor **MUST BE OFF** before going to the next step)
2. Once the motor is completely off, slide the lever to the desired high to low setting. You may run into situations where the level does not fully go into low or high. If so, carefully rotate the blade while trying to put the motor into gear. The lever will fully go into to gear.

Blade Speed Ranges (FPM)	
High Gear Range	1200 – 3500 FPM
Low Gear Range	100 – 290 FPM

- Below is the procedure to change the FPMs of the bandsaw (**SAW ON, AND RUNNING**).
 1. To change to the desired RPM on the bandsaw, the bandsaw **MUST** be on and the blade rotating in the required gear prior changing the speed.
 2. Locate the motor locking level located on the back side of the bandsaw near the bottom by the motor. Loosen the lever handle.
 3. The adjuster hand wheel located on the bottom right of the bandsaw adjusts the blade speed. Referencing to the dial located on the back of the motor.
 4. Slowly rotate the handwheel CW to increase the blade speed, or CCW to decrease the blade speed.
 5. Tighten the motor locking lever back in place immediately.



USE CAUTION: Never start the VDL-18 bandsaw with any slack in the drive belt. Doing so can cause machine damage as the belt is forced to pull through the slack.

Blade Speed Chart

Material	Speed Range (FPM)
Structural Steel Shapes	165
Low Carbon Steel	160-165
Medium Carbon Steel	115
High Carbon Steel	90-100
Cr-moly Steel	105-135
Ni-Cr-moly Steel	90-115
Chromium Steel	80-140
Cr-vanadium Steel	105-115
Tool Steel	40-80
Stainless Steel	40-70
Free Machining Steel	80-100
Cast Iron	55-90
Copper Alloy (Cu-Zm)	55
Bronze	90
Al-Bronze	40
Monel	40-45
Titanium Alloy	25-40
Aluminum (soft)	3000
Aluminum (T-6+)	3000
Carbon	3000
Slate	80-160
PTFE Sheet, Rod, Rounds	3000
Hard Rubber	3000
Plywood	3000
Other Woods	3000

Blade Guidepost Adjustment:

- The following steps are to properly adjust the Blade Guidepost height on the VDL-18 Bandsaw.
 1. Locate the guidepost locking screw located on the rear top half of the bandsaw. To make any adjustments, loosen the locking screw to allow the blade guidepost to freely move horizontally.
 2. The hand wheel located above the blade guidepost on the side of the machine adjusts the horizontal movement of the guidepost.

NOTE: (Maintain a clearance of 3/16 inch between the blade guidepost and the workpiece to allow minimum exposed blade to prevent injury).
 3. After correctly adjusting the height of the blade guidepost, ALWAYS tighten the guidepost screw for the guide will stay in the desired position.

Table Tilt:

- The following steps are to properly adjust the Table Tilt angle on the VDL-18 Bandsaw.
 1. Loosen lock nut and stop bolt until it does not contact the table underneath the worktable.
 2. On both side of the worktable, there are 2 locking levers. Loosen them both then the table is free to move to the desired angle of cut.
 3. Pivot the worktable referencing to the protractor angle to set the angle of cut.
 4. Tighten the level handles, stop bolt, and locking nut to secure the wanted angle. CW is 45 degrees, CCW is 15 degrees degree of freedom.

Fence Assembly Adjustment:

- The following steps are to properly adjust the Fence Assembly Adjustment on the VDL-18 Bandsaw. This will change the accuracy length cut of the workpiece. Check the clearance between the table and the fence. The fence should not rub against the table surface but be slightly above it. This gap should be the same at the front of the table as it is at the rear.
 1. Loosen the fence locking wheel located on the fence assembly.
 2. The fence is now free to move vertically along the worktable.
 3. Once in the desired spot, lock the fence in place by tightening the locking screw.

Top Idler Wheel Camber Adjustment

- This adjustment aligns the tilt of the idler pulley align with the drive pulley. If the wheel seems to be off centered, making noise, follow these steps to properly align the blade.
 1. By a visual explanation, the top idler wheel is not aligning properly and needs to be calibrated. Rotate wheel so that the most inward motion of the wheel is at the bottom dead center of the rotation.
 2. On the back side of the bandsaw, loosen the locking nut located above the tensioning lever.
 3. If the adjusting screw-wheel is tightened, the camber of the wheel will also increase accordingly. If the screw is loosened, the camber would go in the negative direction.
 4. Adjust until the wheel rotates with no vertical wobbling motion is present.

Maintenance

 **Before performing any maintenance to the machine, make sure to unplug the cord from the power source before cleaning.**

- Maintain bearing guides clean and free of build-up.
- Check that the cleaning brush over the band wheel is working properly and remove any deposits from the band wheels to avoid vibration and blade breakage.
- The table surface should be always kept clean and free of rust for best results. talcum powder applied with a blackboard eraser rubbed in vigorously once a week; this will fill casting pores and form a moisture barrier. This method provides a tabletop that is slick and allows rust rings to be easily wiped from the surface.
- Clean and grease all mechanical movement components such as gears, bars, if it becomes difficult to adjust.
- Clean and oil the tensioning mechanism if it becomes difficult to adjust.
- Check the drive V-belt for cracks overtime. Replace if any irregular wear is present.

Trouble Shooting:

Item	Action	Interval	Maintenance
Saw Blade	Listen for sound of missing teeth.	Whenever operating saw	Replace blade when teeth are broken.
	Observe cutting action for cleanness and accuracy.	Whenever operating saw	Replace blade when bent or worn; use a wider blade for more accurate straight cuts.
	Listen for a poor weld – a “click” as it passes through the guide bearings.	When changing blade	Use a different blade or dress the weld with a grinder.
	Watch for signs of slippage on the drive wheels (blade occasionally slows or comes to a stop while sawing).	Whenever sawing	Be sure you are using the correct blade tension; check rubber tires for cleanliness and adherence to drive wheel – replace if necessary.
Lower Drive Wheel	Check bearing area for leakage of lubricant.	Monthly	Replace bearing if leakage occurs.
Upper Drive Wheel	Check bearing area for leakage of lubrication.	Monthly	Replace bearing if leakage occurs.
Drive Wheel Rubber Tires	Check for cleanliness.	Daily and when changing blade	Wipe or brush clean.
Drive Belt	Check for smooth surfaces and adherence to drive wheel. Check for glazing.	Monthly or when blade slippage occurs Monthly, or when slippage occurs (squealing belt)	Clean when necessary – replace if damaged or excessively worn. Replace a glazed belt – DO NOT USE BELT DRESSING.
Gearbox	Check sight glass for level – should be to halfway point on sight glass.	Daily Annually	Fill up to halfway point on sight glass with 90 wt. gear oil. Drain and refill.
Blade Support Bearings	Check for wear, damage, or lubricant leakage.	Monthly and when changing blade	Replace when necessary.
Carbide Blade Guides	Check for excessive wear.	When changing blade	Replace if excessively worn.

Parts List

Upper Wheel Assembly: (Parts List Below)

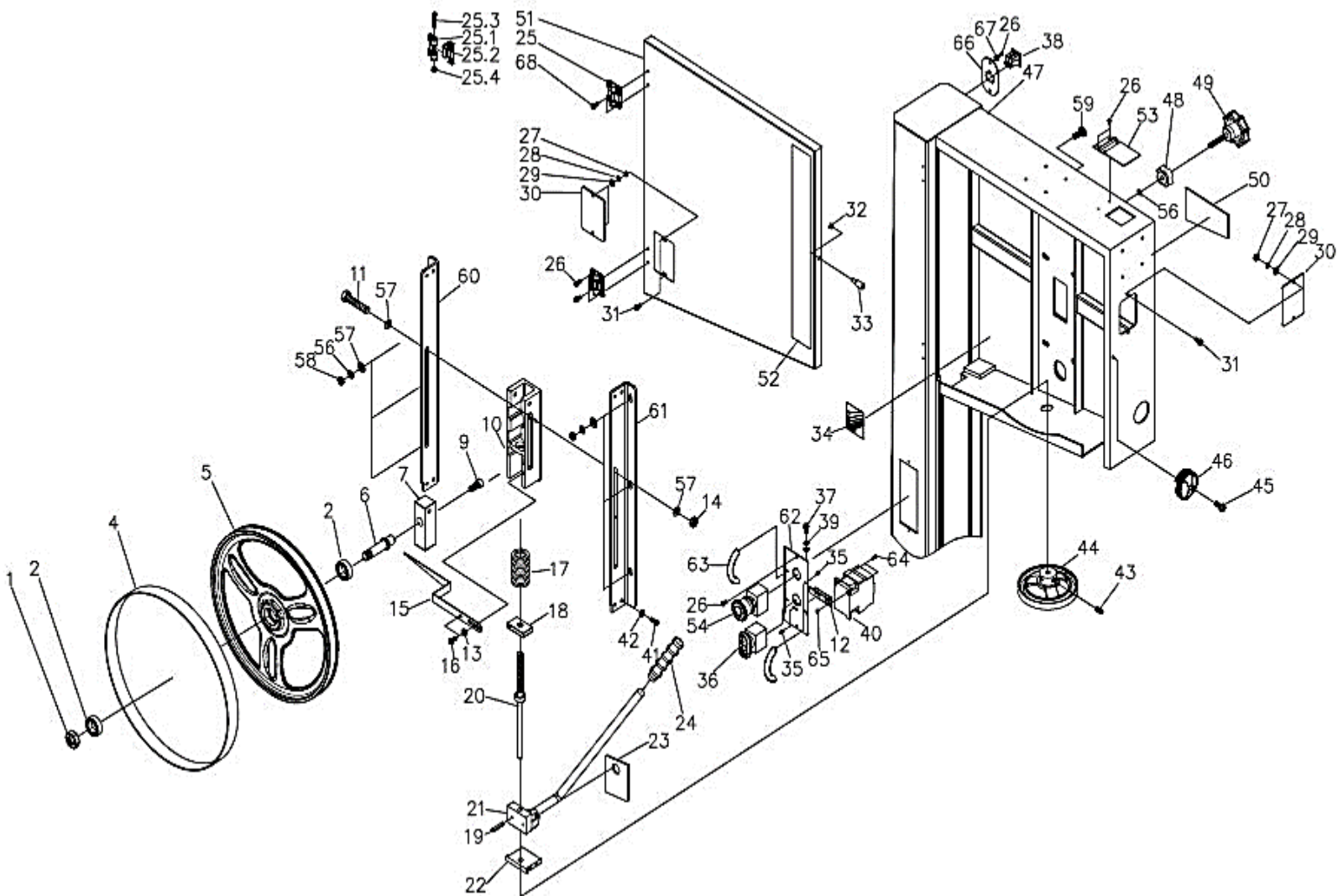



Upper Wheel Assembly

<u>Index</u>	<u>Part Number</u>	<u>Dake Part Number</u>	<u>Item Description</u>	<u>Specifications</u>	<u>Qty</u>
1	PBAND18BX2203-1		Hex Nut	5/8-18UNF-LH	1
2	PBAND18BX2203-2		Ball Bearing	6204LLU	2
4	PBAND18BX2203-4		PU Tire		1
5	PBAND18BX2203-5		Upper Wheel		1
6	PBAND18BX2203-6		Upper Wheel Shaft		1
7	PBAND18BX2203-7		Upper Wheel Shaft Bracket		1
9	PBAND1412-175-9		Socket Head Cap Screw	3/8"-16x5/8"	1
10	PBAND18BX2203-10		Sliding Bracket		1
11	PBAND18BX2203-11		Hex Cap Screw	M8x80	1
12	PBAND1412-175-170		Switch Plate		1
13	PBAND18BX2203-13		Bushing		1
14	PBAND18BX2203-14		Nylon Inserted Lock Nut	M8	1
15	PBAND18BX2203-15		Pointer		1
16	PBAND18BX2203-16		Special Bolt		2
17	PBAND18BX2203-17		Spring		1
18	PBAND18BX2203-18		Bracket		1
19	PBAND1412-175-19		Pin	Ø4x20	1
20	PBAND18BX2203-20		Adjusting Screw		1
21	PBAND18BX2203-21		Blade Tension Arm Assembly		1
22	PBAND18BX2203-22		Support Block		1
23	PBAND1412-175-23		Plate		1
24	PBAND1412-175-24		Handle		1
25	PBAND1412-175-25		Door Hinge Set		2
25.1	PBAND1412-175-25-1		Door Hinge, Left		2
25.2	PBAND1412-175-25-2		Door Hinge, Right		2
25.3	PBAND1412-175-25-3		Socket Head Cap Screw	M5x0.8x35	2
25.4	PBAND1412-175-25-4		Nylon Inserted Lock Nut	M5x0.8	2
26	PBAND1412-175-26		Screw	M3.5x10mm	10
27	PBAND1412-175-27		Hex Nut	#10-24	4
28	PBAND1412-175-28		Lock Washer	#10	4
29	PBAND1412-175-29		Flat Washer	#10	4
30	PBAND1412-175-30		Tracking Window		2
31	PBAND1412-175-31		Screw	#10-24x1/2"	4
32	PBAND1412-175-32		Hex Nut	1/4"-20	1
33	PBAND1412-175-33		Door Stud		1
34	PBAND18BX2203-34		Tension Gauge		1

35	MBAND14BX110-175-35		Phillips Flat Head Screw	M3x6	6
36	MBAND14BX110-175-36		ON/ OFF Switch		1
37	PBAND1412-175-37		Screw	M5x0.8x16	2
38	PBAND1412-175-38		Outlet		1
39	PBAND1412-175-39		Washer, Lock-Int. Tooth	M5	3
40	MBAND14BX110-175-40		Contactora		1
41	PBAND1412-175-41		Hex Cap Screw	1/4"-20x5/8"	4
42	PBAND1412-175-42		Lock Washer	1/4"	4
43	PBAND1412-175-43		Set Screw	1/4"-20x3/8"	2
44	PBAND18BX2203-44		Handwheel		1
45	PBAND1412-175-45		Screw	1/4"-20x3/4"	1
46	PBAND1412-175-46		Lock Knob		1
47	PBAND18CX110175-47		Saw Body		1
48	PBAND1412-175-48		Lock Knob		1
49	PBAND1412-175-49		Adjusting Knob		1
50	PBAND1412-175-50		Tension Label		1
51	PBAND18BX2203-51		Upper Door		1
52	PBAND18CX110175-52		Logo Label		1
53	PBAND1412-175-53		Hinge Cover		1
54	MBAND14BX110-175-54		Emergency Stop		1
55	PBAND1412-175-55		Warning Label		1
56	PBAND1412-175-2-13		Lock Washer	5/16"	7
57	PBAND1412-175-2-11		Flat Washer	5/16"	8
58	PBAND1412-175-3-38		Hex Nut	5/16"-18	6
59	PBAND18BX2203-59		Carriage Bolt	5/16-18x1"	6
60	PBAND18BX2203-60		Upper Wheel Bracket-Left		1
61	PBAND18BX2203-61		Upper Wheel Bracket-Right		1
62	PBAND18CX110175-62		Control Panel		1
63	MBAND14BX110-175-63		Handle		2
64	MBAND14BX110-175-64		Hex Cap Screw	M4x0.7x12	2
65	MBAND14BX110-175-65		Hex Nut	M4x0.7	2
66	MBAND14BX110-175-66		Plate		1
67	MBAND14BX110-175-67		Washer, Lock-Int. Tooth	M4	2
68	MBAND14BX110-175-68		Screw	M4x0.7x8	4

Table and Fence Assembly: (Parts List Below)

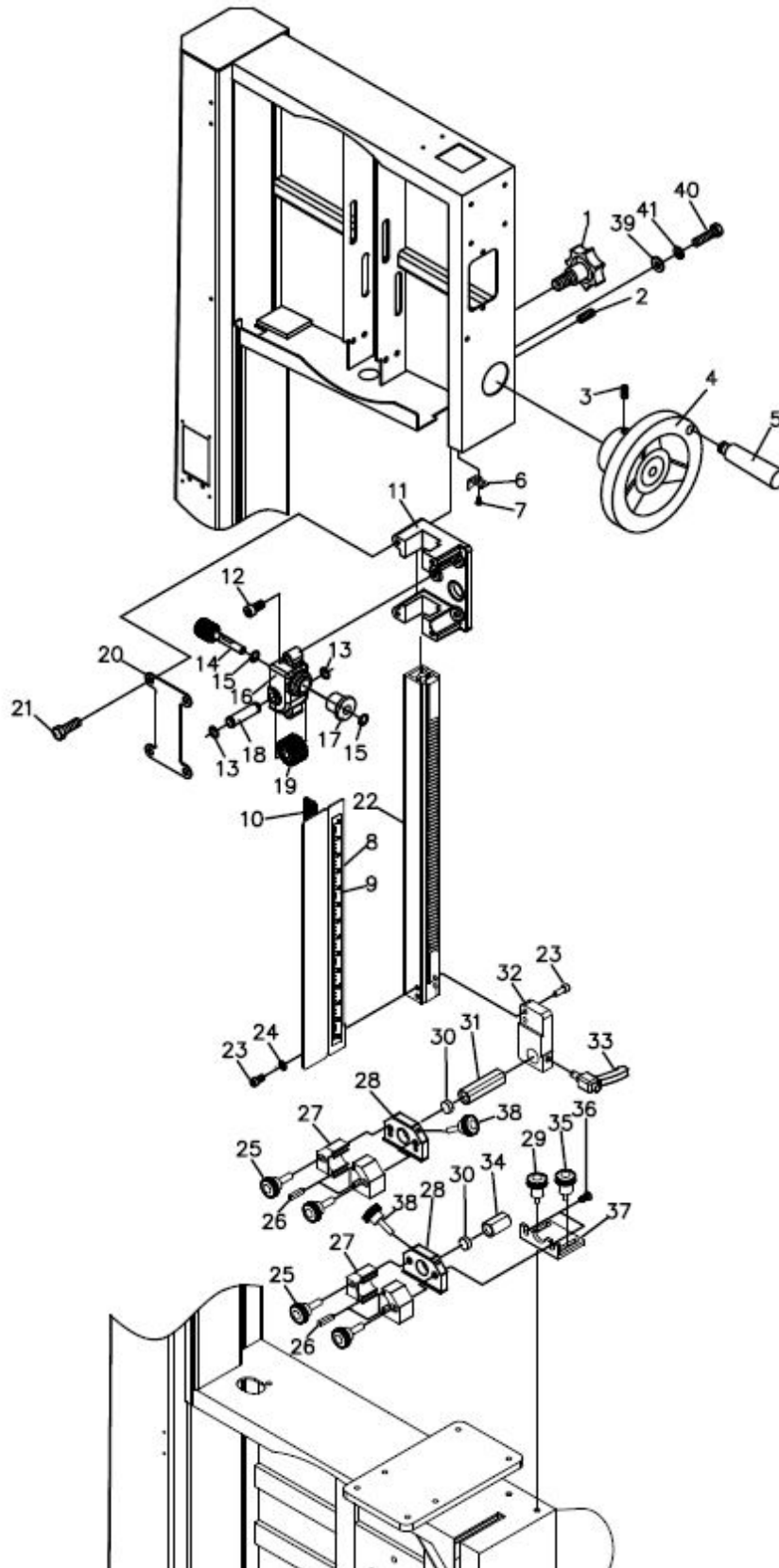



Table & Fence Assembly Parts List

<u>Item</u>	<u>Part Number</u>	<u>Dake Part Number</u>	<u>Item Description</u>	<u>Specifications</u>	<u>Qty</u>
1	PBAND18BX2203-3-1		Aluminum Fence		1
2	PBAND1412-175-3-2		Plastic Adjusting Screw		1
3	PBAND1412-175-3-3		Fence Body		1
4	PBAND1412-175-3-4		Lock Knob		2
5	PBAND1412-175-3-5		Socket Head Cap Screw	5/16"-18x3/4"	3
6	PBAND1412-175-2-13		Lock Washer	5/16"	10
7	PBAND1412-175-3-7		Fence Head		1
8	PBAND18BX2203-3-8		Lock Knob		1
9	PBAND1412-175-3-9		Lock Bar		1
10	PBAND1412-175-3-10		Set Screw	M4x0.7x4	4
11	PBAND1412-175-3-11		Table Insert		1
12	PBAND18BX2203-3-12		Table		1
13	PBAND18BX2203-3-13		Scale		1
14	PBAND18BX2203-3-14		Scale Plate		1
15	PBAND1412-175-3-15		Hex Cap Screw	M5x0.8x10	2
16	PBAND1412-175-29		Flat Washer	M5	2
17	PBAND1412-175-3-17		Bushing		2
18	PBAND1412-175-3-18		Socket Head Cap Screw	5/16"-18x2-1/2"	2
19	PBAND18BX2203-3-19		Steel Tube		1
20	PBAND1412-175-3-20		Scale		1
21	PBAND1412-175-3-21		Trunnion		2
22	PBAND1412-175-3-22		Hex Cap Screw	M10x1.5x50	2
23	PBAND1412-175-3-23		Slide Block		2
24	PBAND1412-175-3-24		Flat Washer	1/4"	6
25	PBAND1412-175-2-42		Lock Washer	1/4"	6
26	PBAND1412-175-3-26		Socket Head Cap Screw	M6x1x16	6
27	PBAND1412-175-3-27		Pointer		1
28	PBAND1412-175-3-28		Screw	M5x0.8x8	1
29	PBAND1412-175-3-29		Bracket		1
30	PBAND1412-175-2-42		Flat Washer	3/8"	2
31	PBAND1412-175-3-31		Lock Handle		2
32	PBAND1412-175-3-32		Hex Cap Screw	5/16"-18x1-1/4"	3
33	PBAND1412-175-3-33		Set Screw	5/16"-18x5/8"	2
34	PBAND1412-175-3-34		Hex Cap Screw	5/16"-18x1-3/4"	3
35	PBAND1412-175-3-35		Hex Cap Screw	3/8"-16x2"	1
36	PBAND1412-175-3-36		Hex Nut	3/8"-16	1
37	PBAND1412-175-3-37		Phillips Flat Head Screw	M4x0.7x8	1
38	PBAND1412-175-3-38		Hex Nut	5/16"-18	1
39	PBAND1412-175-2-11		Flat Washer	5/16"	1
40	PBAND1412-175-3-40		Lock Handle		1



41	PBAND18BX2203-3-41		Nylon Inserted Lock Nut	5/16-18UNC	1
42	PBAND1412-175-3-42		Set Screw	1/4"-20x1/4"	2
43	PBAND18BX2203-3-43		Fence Stop Hinge		1
44	PBAND18BX2203-3-44		Lock Handle		1
45	PBAND18BX2203-3-45		Fence Stop-A		1
46	PBAND18BX2203-3-46		Fence Stop-B		1
47	PBAND1412-175-6-26		Bushing		2
48	PBAND18BX2203-3-48		Socket Head Cap Screw	5/16-18UNCx2"	1
49	PBAND18BX2203-3-49		Square Nut	1/4-20UNC	1
50	PBAND18BX2203-3-50		Screw	M3x0.5x4	2
51	PBAND18BX2203-3-51		Scale		1

Upper & Lower Blade Guides Assembly: (Parts List Below)

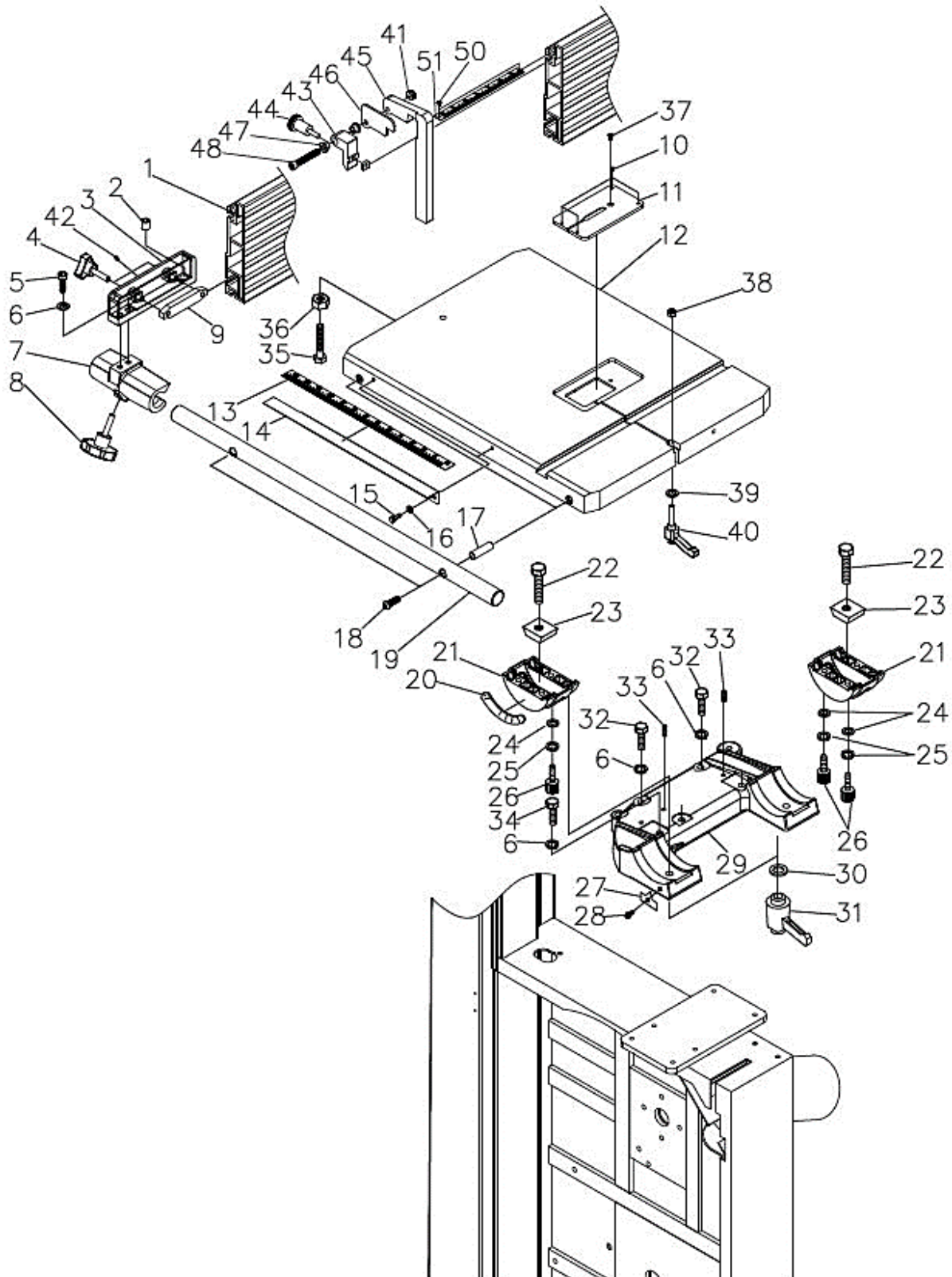



Upper & Lower Blade Guides Assembly Parts List

<u>Item</u>	<u>Part Number</u>	<u>Dake Part Number</u>	<u>Item Description</u>	<u>Specifications</u>	<u>Qty</u>
1	PBAND1412-175-4-1		Lock Knob		1
2	PBAND1412-175-2-8		Set Screw	5/16"-18x3/8"	2
3	PBAND1412-175-4-3		Set Screw	1/4"-20x3/8"	1
4	PBAND1412-175-4-4		Hand wheel		1
5	PBAND1412-175-4-5		Handle		1
6	PBAND18BX2203-4-6		Pointer		1
7	PBAND1412-175-4-7		Screw	1/4"-20x3/8"	1
8	PBAND18BX2203-4-8		Upper Blade Guard		1
9	PBAND18BX2203-4-9		Height Scale		1
10	PBAND18BX2203-4-10		Magnet		1
11	PBAND1412-175-4-11		Guide Bar Bracket		1
12	PBAND1412-175-4-12		Socket Head Cap Screw	5/16"-18x1-1/4"	2
13	PBAND1412-175-4-13		C-Ring	S12	2
14	PBAND1412-175-4-14		Worm		1
15	PBAND1412-175-4-15		E-Ring	E8	2
16	PBAND1412-175-4-16		Gear Base		1
17	PBAND1412-175-4-17		Bushing		1
18	PBAND1412-175-4-18		Shaft		1
19	PBAND1412-175-4-19		Gear		1
20	PBAND1412-175-4-20		Plate		1
21	PBAND1412-175-4-21		Socket Head Button Screw	5/16"-18x1/2"	4
22	PBAND18BX2203-4-22		Guide Bar		1
23	PBAND1412-175-4-23		Socket Head Cap Screw	1/4"-20x5/8"	4
24	PBAND1412-175-4-24		Lock Washer	1/4"	2
25	PBAND1412-175-4-25		Lock Knob		4
26	PBAND1412-175-4-26		Ceramic Guide		8
27	PBAND1412-175-4-27		Adjusting Block		4
28	PBAND1412-175-4-28		Fixed Block		2
29	PBAND1412-175-4-29		Lock Knob		1
30	PBAND1412-175-4-30		Ceramic Guide		2
31	PBAND1412-175-4-31		Support Shaft		1
32	PBAND1412-175-4-32		Guide Bracket		1
33	PBAND1412-175-4-33		Lock Handle		1
34	PBAND1412-175-4-34		Support Shaft		1
35	PBAND1412-175-4-35		Lock Knob		1
36	PBAND1412-175-4-36		Socket Head Button Screw	1/4"-20x1/2"	2
37	PBAND18BX2203-4-37		Base		1
38	PBAND1412-175-4-38		Special Bolt		2
39	PBAND1412-175-2-11		Flat Washer	5/16"	4
40	PBAND1412-175-4-40		Hex Cap Screw	5/16"-18x1"	4
41	PBAND1412-175-2-13		Lock Washer	5/16"	4

Lower Wheel & Motor Assembly: (Parts List Below)

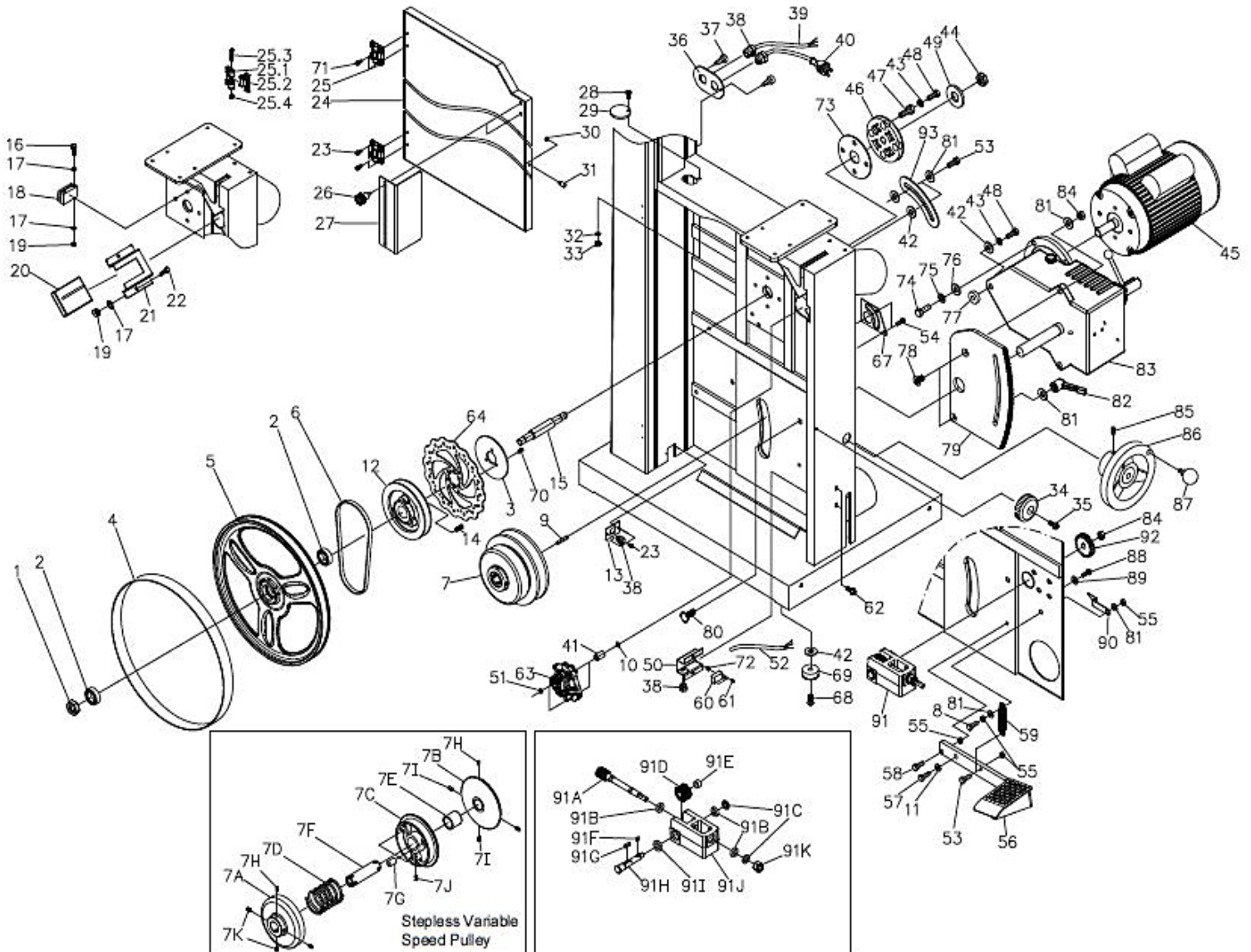



Lower Wheel & Motor Assembly Parts List

<u>Item</u>	<u>Part Number</u>	<u>Dake Part Number</u>	<u>Item Description</u>	<u>Specifications</u>	<u>Qty</u>
1	PBAND18BX2203-1		Hex Nut	5/8-18UNF-LH	1
2	PBAND18BX2203-2		Ball Bearing	6204LLU	2
3	PBAND18BX2203-2-3		Plate		1
4	PBAND18BX2203-4		PU Tire		1
5	PBAND18BX2203-2-5		Lower Wheel		1
6	PBAND18CX110175-2-6		V-Belt		1
7	PBAND18CX110175-2-7		Motor Pulley, Variable Speed		1
7A	PBAND18CX110175-2-7A		Motor Pulley, Cover		1
7B	PBAND18CX110175-2-7B		Motor Pulley, Holder		1
7C	PBAND18CX110175-2-7C		Motor Pulley, Slide		1
7D	PBAND18CX110175-2-7D		Motor Pulley, Spring		1
7E	PBAND18CX110175-2-7E		Motor Pulley, Bushing		1
7F	PBAND18CX110175-2-7F		Motor Pulley, Coupling		1
7G	PBAND18CX110175-2-7G		Motor Pulley, Plastic Support Post		3
7H	PBAND1412-175-2-8		Motor Pulley, Set Screw	5/16"-18x3/8"	4
7I	PBAND18CX110175-2-7I		Motor Pulley, Pin	6x16	2
7J	PBAND18CX110175-2-7J		Motor Pulley, Pin	5x10	1
7K	PBAND18CX110175-2-7k		Motor Pulley, Pin	6x12	2
8	PBAND18CX110175-2-8		Hex Cap Screw	3/8-16UNCx1-3/4"	1
9	PBAND18CX110175-2-9		Key	7x7x100	1
10	MBAND14BX110-175-2-10		Flat Washer	1/4"	2
76	PBAND1412-175-2-11		Flat Washer	5/16"	2
12	PBAND18CX110175-2-12		Spindle Pulley		1
13	MBAND14BX110-175-2-13		Plate		1
14	MBAND14BX110-175-2-14		Phillips Flat Head Screw	5/16"-18x1-1/2"	3
15	PBAND18BX2203-2-15		Lower Spindle		1
16	PBAND1412-175-2-16		Hex Cap Screw	M5x0.8x30	2
17	PBAND1412-175-29		Flat Washer	M5	6
18	PBAND1412-175-2-18		Brush		1
19	PBAND1412-175-2-19		Hex Nut	M5x0.8	4
20	PBAND1412-175-2-20		Insert Block		1
21	PBAND1412-175-2-21		Shelf		1
22	PBAND1412-175-2-22		Hex Cap Screw	M5x0.8x12	2
23	PBAND1412-175-26		Screw	M3.5x10mm	6
24	PBAND18BX2203-2-24		Lower Door		1
25	PBAND1412-175-25		Door Hinge Set		2
25.1	PBAND1412-175-25-1		Door Hinge, Left		2
25.2	PBAND1412-175-25-2		Door Hinge, Right		2
25.3	PBAND1412-175-25-3		Socket Head Cap Screw	M5x0.8x35	2



25.4	PBAND1412-175-25-4		Nylon Inserted Lock Nut	M5x0.8	2
26	PBAND1412-175-2-26		Lock Knob		2
27	PBAND18BX2203-2-27		Lower Blade Guard		1
28	PBAND1412-175-2-28		Screw	1/4"-20x3/4"	1
29	PBAND1412-175-2-29		Plate		1
30	PBAND1412-175-32		Hex Nut	1/4"-20	1
31	PBAND1412-175-33		Door Stud		1
32	PBAND1412-175-2-32		Flat Washer	1/4"	1
33	PBAND1412-175-2-33		Nylon Inserted Lock Nut	1/4"-20	1
34	PBAND1412-175-46		Lock Knob		1
35	PBAND1412-175-45		Screw	1/4"-20x3/4"	1
36	PBAND1412-175-2-36		Plate		1
37	PBAND1412-175-2-37		Screw	#10-24x3/8"	2
38	PBAND1412-175-2-38		Strain Relief	6N-4	4
39	MBAND14BX110-175-2-39		Motor Cord		1
40	MBAND14BX110-175-2-40		Power Cord		1
41	MBAND14BX110-175-2-76		Bushing		2
42	PBAND1412-175-2-42		Flat Washer	3/8"	7
43	PBAND1412-175-8		Lock Washer	3/8"	5
44	PBAND18BX2203-2-44		Hex Nut	3/4"-16UNF	1
45	PBAND18CX110175-2-45		Motor		1
	MBAND14BX110-175-2-45MF		Motor Fan (not shown)		1
	MBAND14BX110-175-2-45MFC		Motor Fan Cover (not shown)		1
	MBAND14BX110-175-2-45JB		Junction Box (not shown)		1
	MBAND14BX110-175-2-45JBC		Junction Box Cover (not shown)		1
46	PBAND1412-175-2-46		Spindle Holder		1
47	PBAND1412-175-2-47		Adjusting Screw		4
48	PBAND1412-175-2-48		Hex Cap Screw	3/8"-16x1-3/4"	5
49	PBAND18BX2203-2-49		Flat Washer	3/4"	1
50	PBAND18BX2203-2-50		Switch Cover		1
51	MBAND14BX110-175-2-51		Hex Nut	M6x1.0	2
52	MBAND14BX110-175-2-52		Limited Switch Cord		1
53	MBAND14BX110-175-2-53		Hex Cap Screw	3/8"-16x3/4"	3
54	MBAND14BX110-175-2-54		Hex Cap Screw	M6x1.0x35	2
55	PBAND1412-175-3-36		Hex Nut	3/8"-16	4
56	PBAND18CX110175-2-56		Foot Brake		1
57	MBAND14BX110-175-2-57		Hex Cap Screw	5/16-18UNCx1/2	1
58	MBAND14BX110-175-2-58		Hex Cap Screw	3/8-16UNCx1-1/4"	1
59	MBAND14BX110-175-2-59		Spring		1
60	MBAND14BX110-175-2-60		Limited Switch		1



61	MBAND14BX110-175-2-61		Screw	M3×20mm	2
62	MBAND14BX110-175-2-62		Screw	1/4"-20x3/8"	2
63	MBAND14BX110-175-2-63		Brake Assembly		1
	MBAND14BX110-175-2-63P		Brake Pad (not shown), 2 pieces		
64	MBAND14BX110-175-2-64		Disc		1
65	MBAND14BX110-175-2-65		Inner Cable		1
66	MBAND14BX110-175-2-66		Housing		1
67	MBAND14BX110-175-2-67		Plate		1
68	MBAND14BX110-175-2-68		Socket Head Button Screw	3/8"-16 x1"	4
69	MBAND14BX110-175-2-69		Rubber Pad		4
70	MBAND14BX110-175-2-70		Socket Head Button Screw	M5x0.8x12	3
71	MBAND14BX110-175-68		Screw	M4x0.7x8	4
72	MBAND14BX110-175-2-72		Spacer		2
73	MBAND14BX110-175-2-73		Plate		1
74	PBAND1412-175-4-40		Hex Cap Screw	5/16-18UNCx1"	4
75	PBAND1412-175-2-13		Lock Washer	5/16"	4
76	PBAND1412-175-2-11		Flat Washer	5/16"	4
77	PBAND18CX110175-2-77		spacer sleeve		1
78	PBAND18CX110175-2-78		Phillips Flat Head Screw	3/8-16UNCx1-1/2"	2
79	PBAND18CX110175-2-79		Gear Plate		1
80	PBAND18CX110175-2-80		Carriage Bolt	3/8-16UNCx1-1/4"	1
81	PBAND18CX110175-2-81		Flat Washer	3/8"	7
82	PBAND18CX110175-2-82		Lock Handle		1
83	PBAND18CX110175-2-83		Gear Box Assembly		1
84	PBAND18CX110175-2-84		Nylon Inserted Lock Nut	3/8-16UNC	3
85	PBAND1412-175-43		Set Screw	1/4"-20UNCx3/8"	1
86	PBAND18CX110175-2-86		Handwheel		1
87	PBAND18CX110175-2-87		Knob		1
88	PBAND18CX110175-2-88		Hex Cap Screw	5/16-18UNCx5/8"	4
89	PBAND18CX110175-2-89		Flat Washer	5/16"	4
90	PBAND18CX110175-2-90		Pointer		1
91	PBAND18CX110175-2-91		Worm Gear Assembly		1
91A	PBAND18CX110175-2-91A		Worm		1
91B	PBAND18CX110175-2-91B		Ball Bearing	6801ZZ	3
91C	PBAND18CX110175-2-91C		spacer sleeve		2
91D	PBAND18CX110175-2-91D		Gear		1
91E	PBAND18CX110175-2-91E		spacer sleeve		1
91F	PBAND18CX110175-2-91F		Key	4x4x8mm	1
91G	PBAND18CX110175-2-91G		Key	4x4x18mm	1
91H	PBAND18CX110175-2-91H		Shaft		1



91I	PBAND18CX110175-2-91I		Ball Bearing	6802ZZ	1
91J	PBAND18CX110175-2-91J		Gear Bracket		1
91K	PBAND18CX110175-2-91K		Nylon Inserted Lock Nut	M12x1.75	1
92	PBAND18CX110175-2-92		Gear		1
93	PBAND18CX110175-2-93		Plate		1
94	PBAND18CX110175-2-94		Speed Label		1

Order Information

- *Please contact factory for current prices*
- Parts are available for direct purchase from Dake or through a distributor. When placing a parts order, you will need to provide the part number, name of part, and model number. All parts shipped F.O.B. Factory in Grand Haven, MI.
- If a customer has any questions or concerns regarding a Dake product that was purchased, please email customer service at customerservice@dakecorp.com

VDL-18 Wiring Diagram:

