

SawStop[®]

Job Site Cart

OWNER'S MANUAL



Model CNS-JSC

Warranty

SawStop warrants to the original retail purchaser of the job site cart accompanying this manual that the job site cart will be free from defects in material and workmanship for ONE YEAR from the date of purchase. This warranty does not apply to defects arising from misuse, abuse, negligence, accidents, normal wear-and-tear, unauthorized repair or alteration, or lack of maintenance.

Please contact SawStop to take advantage of this warranty. If SawStop determines the job site cart is defective in material or workmanship, and not due to misuse, abuse, negligence, accidents, normal wear-and-tear, unauthorized repair or alteration, or lack of maintenance, then SawStop will, at its expense and upon proof of purchase, send replacement parts to the original retail purchaser necessary to cure the defect. Alternatively, SawStop will repair the job site cart, provided it is returned to SawStop, shipping prepaid, within the warranty period. This warranty is void if the job site cart is modified without the prior permission of SawStop, LLC, or if the job site cart is located or has been used outside of the country where the authorized SawStop distributor from whom the job site cart was purchased resides.

SawStop disclaims any and all other express or implied warranties, including merchantability and fitness for a particular purpose. SawStop shall not be liable for death, injuries to persons or property, or incidental, consequential, contingent or special damages arising from the use of the job site cart.

This warranty gives you specific legal rights. You may have other rights which vary from state to state.

Safety

1. Do not attempt to use or move the saw on an inclined surface. The weight of the saw makes it difficult to stop on an inclined surface. Attempting to use or move the saw on an inclined surface could result in a severe injury.
2. Be sure to unplug or disconnect the saw from power before moving or repositioning it. The main power cord or the power outlet could be damaged if the saw is not disconnected from power before moving it.
3. While moving the saw, only lift the job site cart handle to waist-height. Do not lift the handle higher or the saw could tip on end.
4. Make sure the job site cart and saw are fully lowered to the ground and stable before operating the saw. Otherwise, the saw could move unexpectedly and cause a severe injury.
5. Lower the saw slowly, do not let it drop back to the ground.

Note: Do not use the *SawStop*® Job Site Cart with a saw having a 36" or 52" T-Glide™ Fence System attached. A 36" or 52" fence system will change the balance of the saw and make the job site cart unstable. The job site cart is designed to be used with the *SawStop*® Contractor Fence Assembly only.

Note: If you have a SawStop 30" Out-Feed Table attached to your saw, you must remove it before using the job site cart to move your saw or you can damage the out-feed table.

Unpacking Your Job Site Cart

While unpacking your job site cart verify that all the components shown on this page are included.

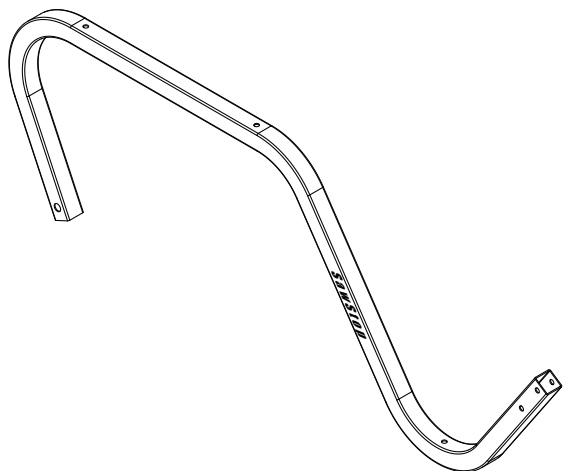

side frame
(two)

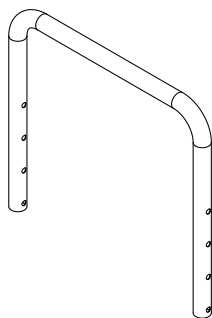

handle

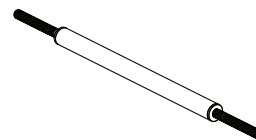

wheel axle

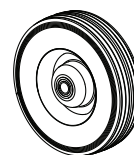

10" wheel
(two)



handle adaptor
(two)

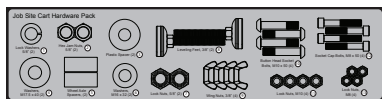

hardware pack



6 mm hex key



owner's manual

Assembling Your Job Site Cart

1. Locate all of the job site cart components shown on page 1. All of the hardware needed to assemble the job site cart is located on the included hardware pack (see Fig. 1). In order to easily identify the hardware used in each of the following steps, the different pieces of hardware are numbered on the hardware pack and in the figures. If you are missing the hardware pack or any of the other job site cart components, call the SawStop Service Department at 503-682-6222 for replacements.

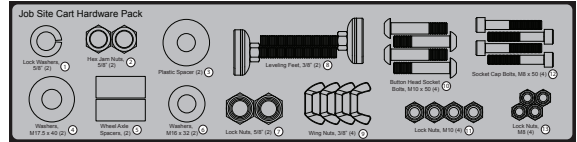

Fig. 1

You will need the following tools to assemble the job site cart:

- a 1 inch wrench or an adjustable wrench
- a 13 mm wrench
- a 17 mm wrench
- a 6 mm hex key

2. Insert one end of the wheel axle through the axle hole in one side frame. Use one $\frac{5}{8}$ lock washer and one $\frac{5}{8}$ inch hex jam nut to secure the axle to the frame, as shown in Fig. 2. Fully tighten the nut using either a 1 inch wrench or an adjustable wrench.

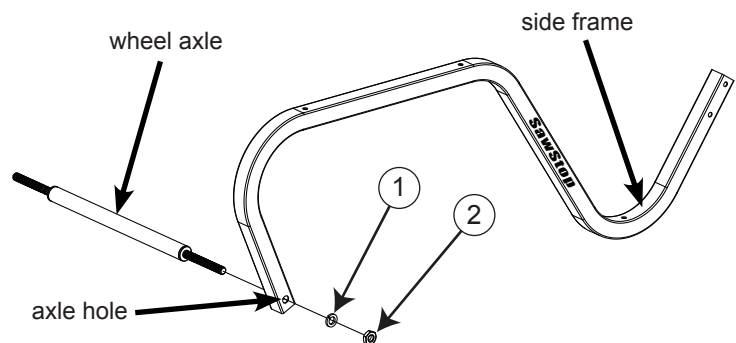

Fig. 2

3. Repeat the same procedure to mount the other side frame to the other end of the wheel axle (see Fig. 3).

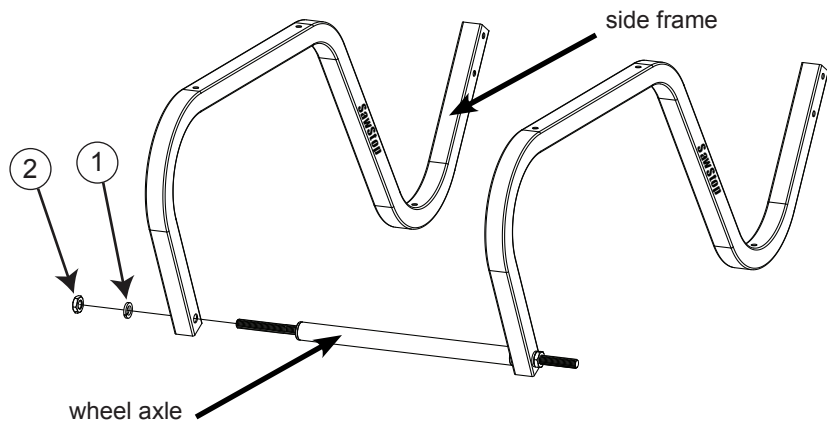
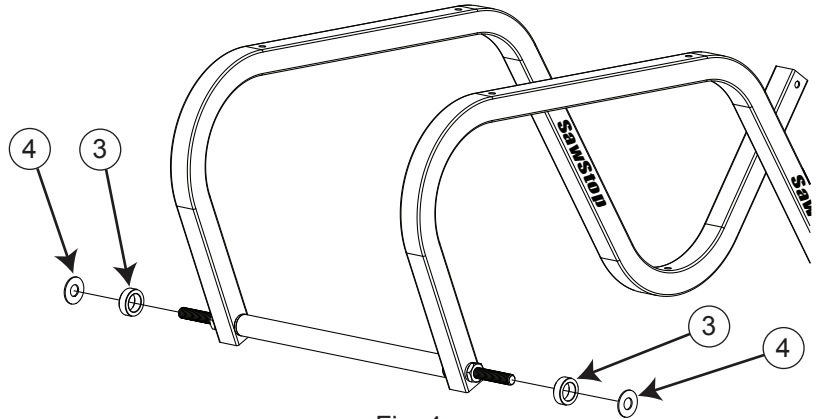

Fig. 3

Assembling Your Job Site Cart

4. Install one plastic spacer and one M17.5 x 40 washer over each end of the wheel axle as shown in Fig. 4.



5. Slide one wheel axle spacer onto each end of the wheel axle as shown in Fig. 5a. Then slide one 10 inch wheel over each wheel axle spacer. Be sure that the side of the wheel with the raised interior is facing inward towards the frame (see Fig. 5b). If the wheel is installed incorrectly it will rub against the side frame.

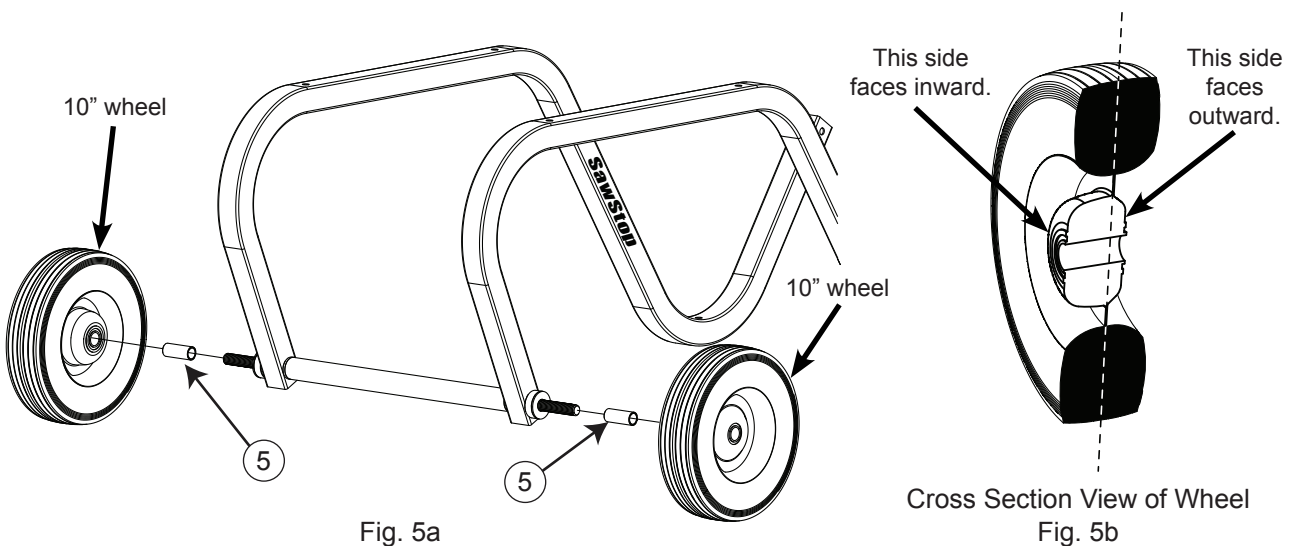

6. Secure each wheel to the wheel axle with one M16 x 32 washer and one 5/8 inch lock nut (see Fig. 6). Fully tighten the lock nuts with a 1 inch wrench or an adjustable wrench.

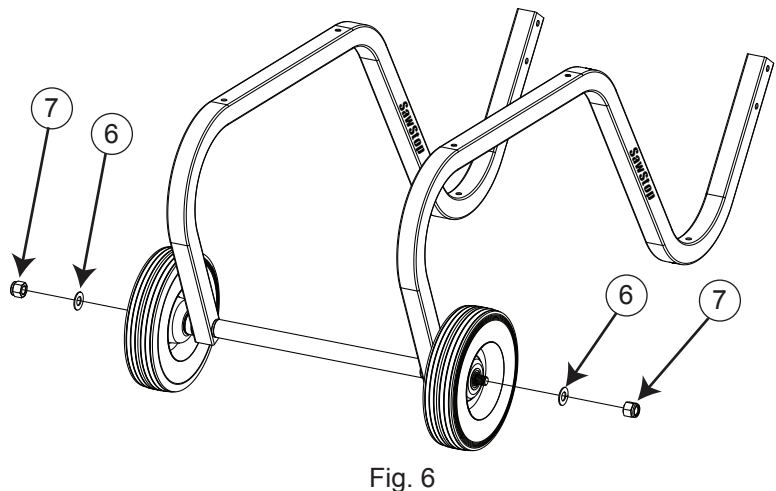

Assembling Your Job Site Cart

- Attach a leveling foot to each side frame with two $\frac{3}{8}$ inch wing nuts, as shown in Fig. 7. First thread a wing nut over each foot with the wings extending toward the bottom of the foot, as shown, then insert one foot into the hole in each side frame, and thread a second wing nut onto each foot. Do not fully tighten the wing nuts at this time.

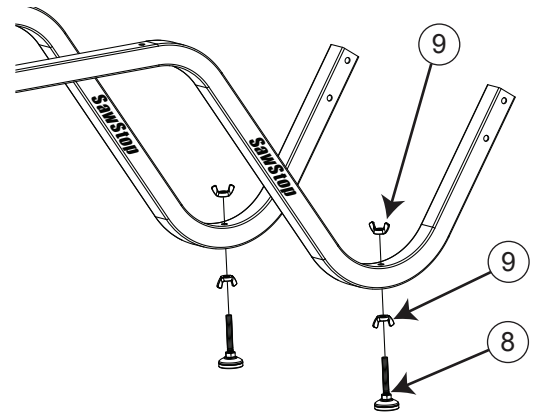

Fig. 7

- Insert one handle adaptor into the open end of each side frame, as shown in Fig. 8, making sure each adaptor is oriented so that its holes align with the holes in the side frame. Then insert the handle into the two adaptors until two of the holes in each end of the handle align with the holes in each side frame. Each end of the handle has four holes so the handle can be set at one of three different heights. Choose whichever height is most comfortable.

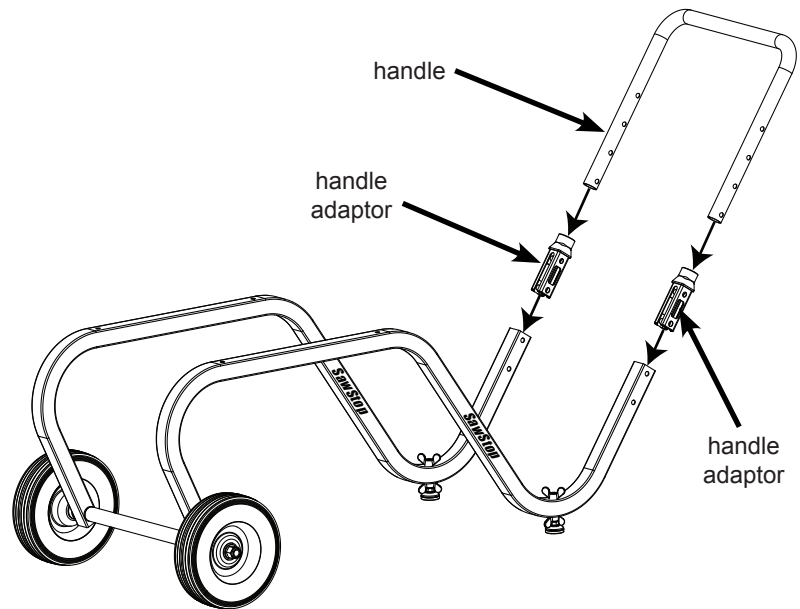

Fig. 8

- Use a 17 mm wrench and the included 6 mm hex key to mount the handle in place with four M10 x 50 button head socket bolts and four M10 lock nuts (see in Fig. 9).

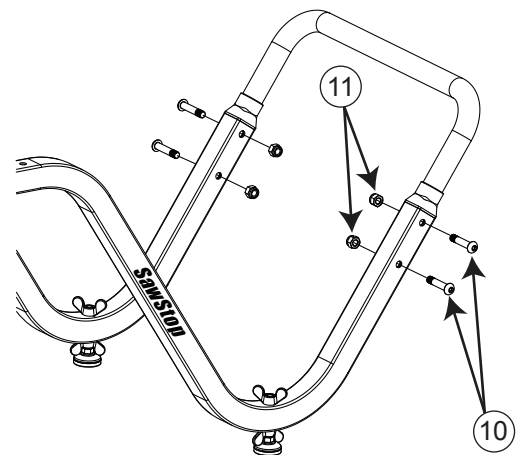

Fig. 9

Assembling Your Job Site Cart

10. The job site cart is now ready to support a SawStop® Contractor Saw. With the help of an assistant, pick up the saw and carefully set it on the job site cart. Make sure the front of the saw is oriented so that the job site cart handle is to the right, as shown in Fig. 10. While moving the saw do not set it down in the upright position on a solid surface because a dust shroud in the saw extends beneath the bottom edge and could be damaged.

WARNING! The saw weighs approximately 140 pounds. Be careful and use proper lifting technique to avoid injury.

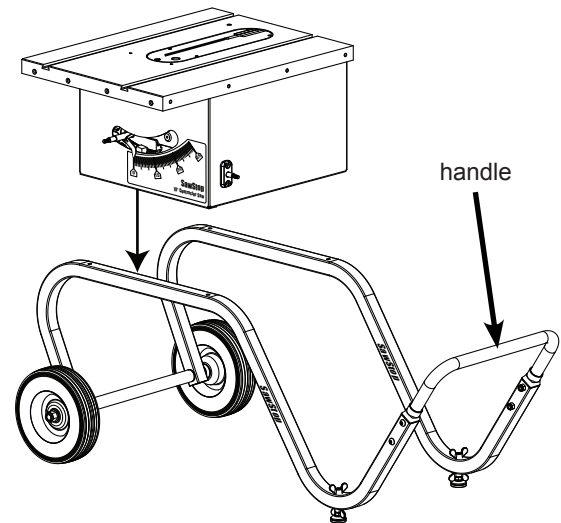

Fig. 10

11. Align the mounting holes in the bottom corners of the saw with the mounting holes in the top surfaces of the job site cart. Mount the saw to the job site cart using four M8 x 50 socket cap bolts and four M8 lock nuts. Insert the bolts down through the mounting holes in the bottom corners of the saw and through the four holes in the job site cart frame (see Fig. 11). Fully tighten the nuts using a 13 mm wrench and a 6 mm hex key.

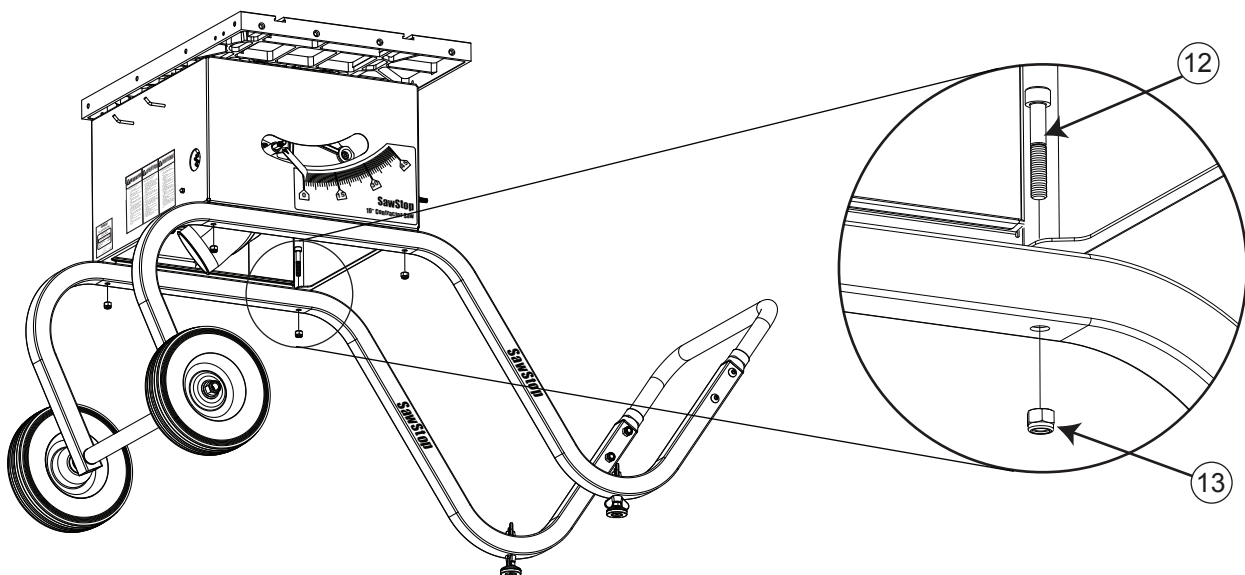

Fig. 11

Assembling Your Job Site Cart

12. If your saw is new, remove the plastic covering from the cast iron table top and remove the yellow label from the top of the table insert. Wipe the oil off the table top with a soft, clean cloth (see Fig. 12). The table top is shipped with a coating of oil to prevent the cast iron from rusting.

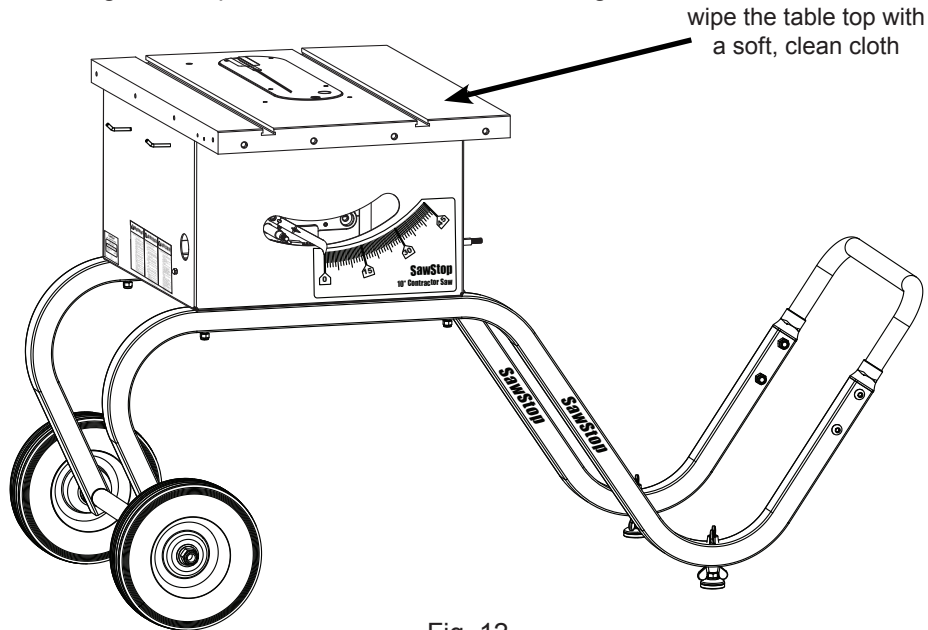

Fig. 12

13. Place a level across the table top and adjust the two leveling feet of the job site cart by turning the lower wing nuts until the table top is level (you may need to loosen the upper wing nuts). When the saw is level, tighten the four wing nuts by hand (see Fig. 13).

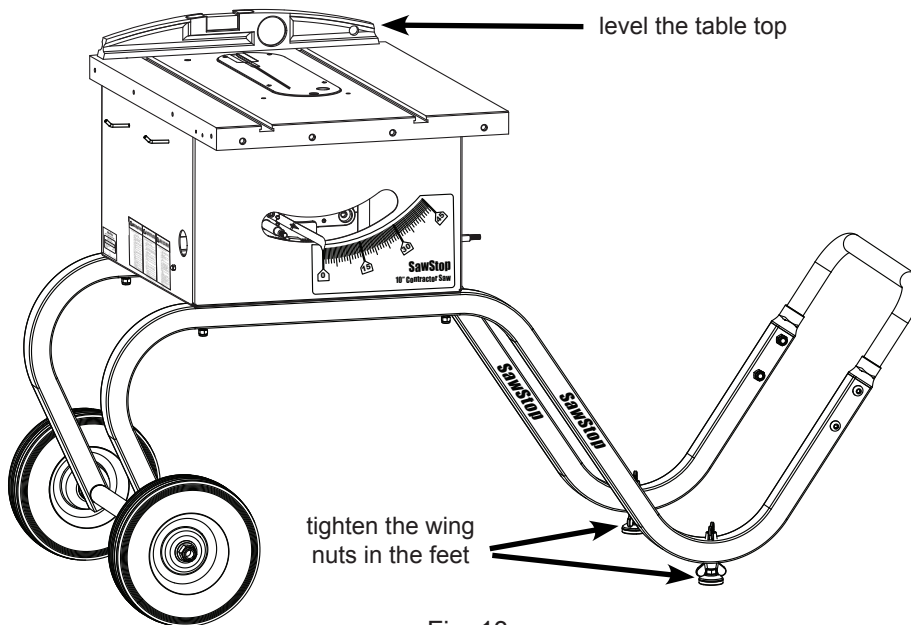

Fig. 13

Congratulations, your job site cart is now assembled. If your saw is new, proceed to step 15 in your contractor saw assembly instructions to complete the assembly of your saw.

Using Your Job Site Cart

Note: If you have a SawStop 30" Out-Feed Table attached to your saw, you must remove it before using the job site cart to move your saw or you can damage the out-feed table.

To move your saw with the job site cart, lift up on the handle until the leveling feet are off the ground and only the 10 inch wheels are in contact with the ground (see Fig. 14). Move the saw to its desired location and then gently lower the saw back down onto the leveling feet.

Warning: Be careful not to lift the handle too high or the saw could tip on end.

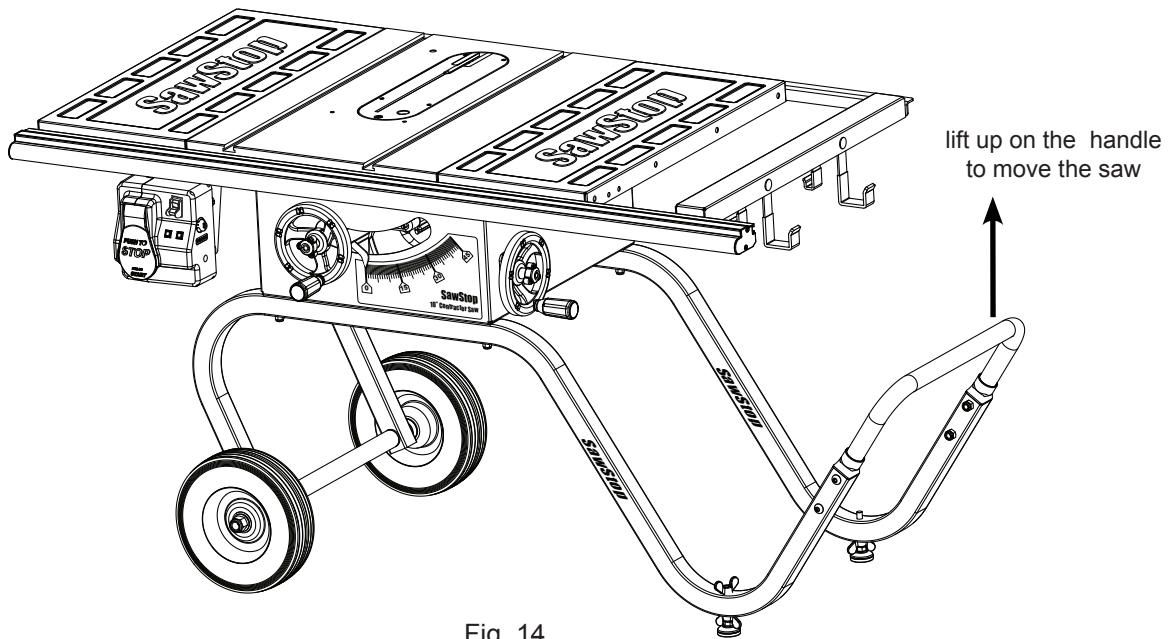

Fig. 14

Moving Your Contractor Saw Through a Doorway

Your contractor saw and job site cart are designed to fit through a standard 36" exterior door frame with the motor removed. The following procedure describes how to remove the motor:

- Remove the motor belt by opening the belt guard and lifting the motor up to release tension on the belt (see Fig. 15).
- Remove the motor from the saw by loosening the two lock down set screws that hold the motor in place (requires a 3 mm hex key), and then slide the motor away from the saw until the motor's mounting pins clear the corresponding holes in the rear trunnion.

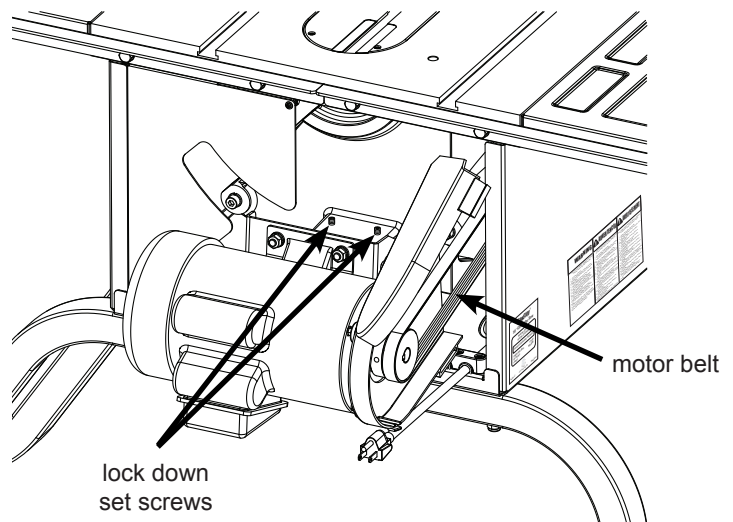
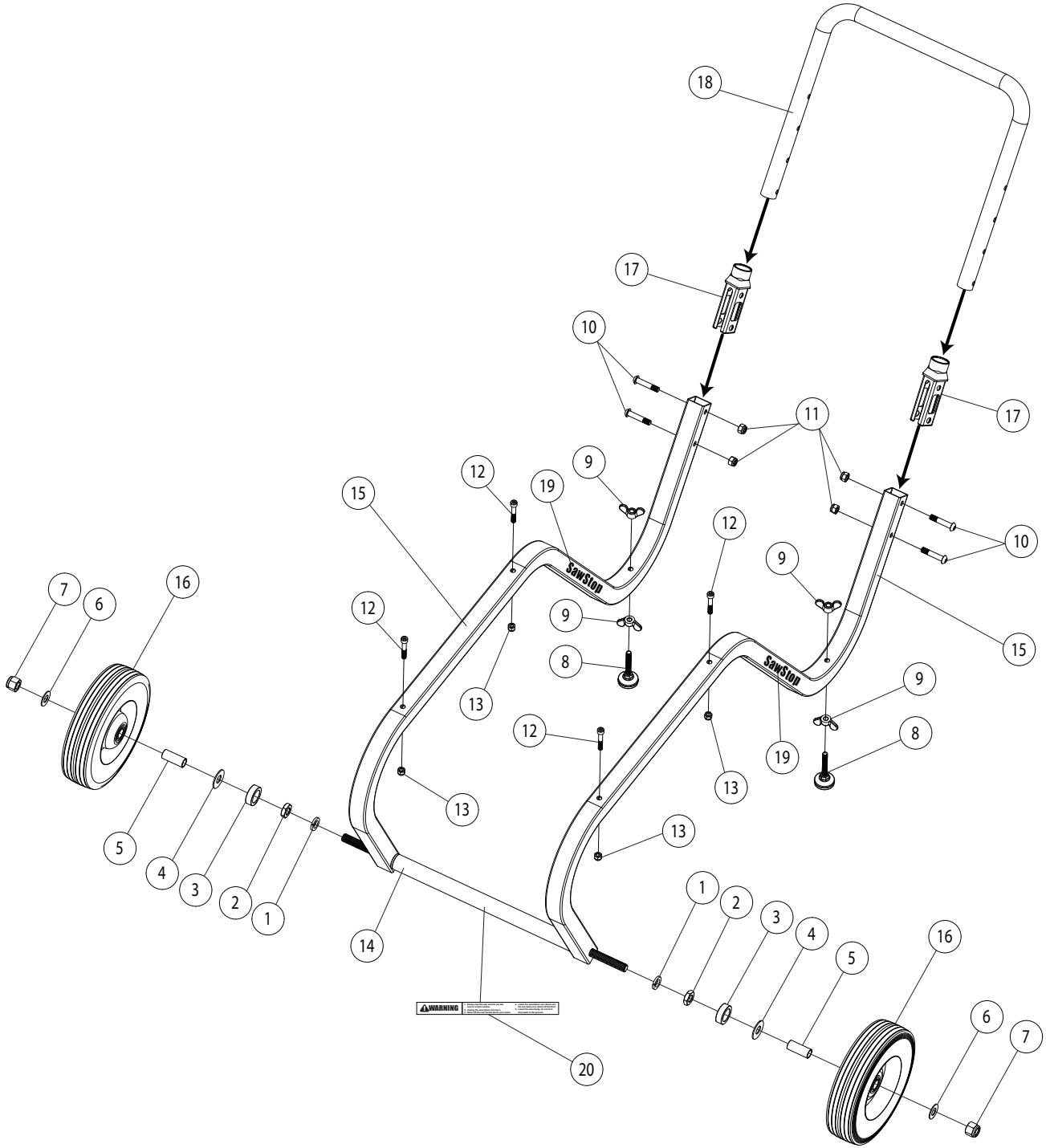

Fig. 15

Job Site Cart Exploded View



Job Site Cart Parts List

No.	Description	Part No.	Qty.
	Job Site Cart Assembly	CNS-JSC	1
1	5/8" Lock Washer	CNS-JSC-001	2
2	5/8" Hex Jam Nut	CNS-JSC-002	2
3	Plastic Spacer	CNS-JSC-003	2
4	M17.5x40 Washer	CNS-JSC-004	2
5	Wheel Axle Spacer	CNS-JSC-005	2
6	M16x32 Washer	CNS-JSC-006	2
7	5/8" Lock Nut	CNS-JSC-007	2
8	Leveling Foot	CNS-JSC-008	2
9	3/8" Wing Nut	CNS-JSC-009	4
10	M10x50 Button Head Socket Bolt	CNS-JSC-010	4
11	M10 Lock Nut	CNS-JSC-011	4
12	M8x50 Socket Cap Bolt	CNS-JSC-012	4
13	M8 Lock Nut	CNS-JSC-013	4
14	Wheel Axle	CNS-JSC-014	1
15	Side Frame	CNS-JSC-015	2
16	10" Wheel	CNS-JSC-016	2
17	Handle Adaptor	CNS-JSC-017	2
18	Handle	CNS-JSC-018	1
19	SawStop Label	CNS-JSC-019	2
20	Warning Label	CNS-JSC-020	1
N/A	Owner's Manual	CNS-JSC-021	1
N/A	Hardware Pack	CNS-JSC-022	1
N/A	6 mm Hex Key	CNS-JSC-023	1

SawStop, LLC
9564 S.W. Tualatin Road
Tualatin, Oregon 97062
www.sawstop.com

Main Phone - (503) 570-3200
Service - (503) 682-6222
Fax - (503) 570-3303
Email: info@sawstop.com

Updates of this manual may be available at www.sawstop.com.

© SawStop, LLC
All Rights Reserved.

July 2008