

# MODEL 960-272

## 8" CONTACT WHEEL

### PARTS LIST

BURR KING

1220 TAMARA LANE  
WARSAW, MO. 65355

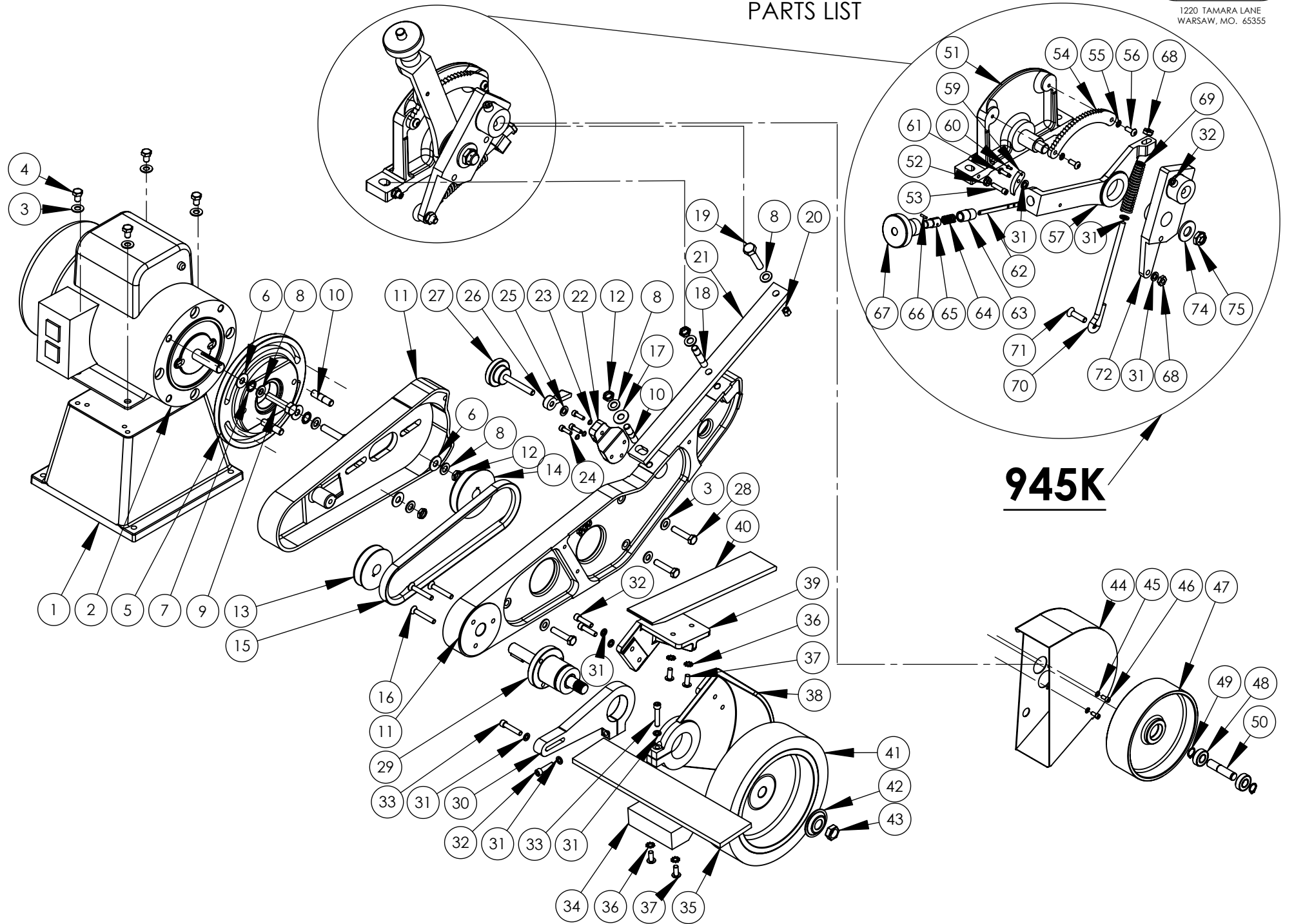

**945K**

**960-272**

ITEM NO.	PART NUMBER	DESCRIPTION	QTY.
1	941	BASE	1
2	MOTOR	CALL FACTORY *	1
3	4	WASHER, 5/16 SAE ZINC PLTD	7
4	2	BOLT, 5/16-18x1 1/2 HEX HEAD	4
5	908	ADAPTER, C-FACE MOTOR	1
6	42	WASHER, SAE, 3/8	4
7	5-0014	WASHER, LOCK 3/8, INTERNAL STAR	2
8	17	WASHER, 960-616, AN	7
9	1-0003	BOLT 3/8-16 x 1 1/4 HEX HEAD	2
10	920	STUD 3/8"x1 1/2", DOUBLE	3
11	900A	FRAME/GUARD ASSEMB	1
12	39	NUT, 3/8-24, JAM, ESNA, NTE	4
13	725	PULLEY, 2 1/2	1
14	730	PULLEY, 3	1
15	429K	BELT, V DRIVE	1
16	6	SCREW 1/4-20 x 1 1/2 FH SOC	3
17	40	WASHER, SAE, 3/8	1
18	920K	STUD 3/8"x1 1/2", DOUBLE	1
19	1-0004	BOLT 3/8-16 x 1 1/4 HEX HEAD	1
20	4-0007	NUT, 3/8-16, ELASTIC LOCK GD 2	1
21	943	BAR, EXTENSION	1
22	923	BRACKET, TRACKING	1
23	5-0035	WASHER, #10, LOCK, HIGH COLLAR	3
24	2-0023	SCREW, 10-24 X .625 ALLEN HEAD	3
25	18	WASHER, 960-516, AN	1
26	922	LOCK, KNOB, TRACKING	1
27	921	KNOB, TRACKING ASSY	1
28	1-0019	BOLT, 5/16-18x1 1/2 HEX HEAD	3
29	701	HOUSING, BEARING, w/keyway	1
30	916-1	ARM, WORKREST SUPPORT	1
31	5	WASHER, 1/4 AN	8
32	30	SCREW 1/4-20x1 SHCS	4
33	31	SCREW 1/4-20x1 1/4 SHCS	2
34	917	WORKREST	1
35	966-01	REST EXTENDER	1
36	5-0008	WASHER, 1/4, LOCK, EXTERNAL	4
37	2-0046	SCREW, 1/4-28x1/2 BH, BLK OX	4
38	903K	GUARD, CONTACT WHEEL	1
39	904BK	BRACKEN, PLATEN	1
40	964-01	PLATEN, MAIN 272	1
41	902	WHEEL, CONTACT	1
42	726	FLANGE, OUTER WHEEL	1
43	727	NUT, 5/8-18 RH, JAM, BRT PLT	1
44	912	GUARD, IDLER WHEEL	1
45	5-0032	WASHER, 1/4, LOCK, SPLIT, PLTD	2
46	1431	SCREW, 1/4-20 x 1/2 ALLEN HEAD	2
47	907K	WHEEL, IDLER, w/Brg. & Shaff	1
48	701B	BEARING	1
49	701F	RING, RETAINING 5/8 EXT.	2
50	707c	SHAFT, BEARING	1

**945K**

ITEM NO.	PART NUMBER	DESCRIPTION	QTY.
51	934	SUPPORT, REAR WHL, w/STUD	1
52	14	NUT, 10-24, KEP	1
53	13	SCREW, 10-24 x 3/4, SOC, HD, CAP	1
54	736	SECTOR	1
55	15	WASHER, 5/16 LOCK, SPLIT	2
56	9	SCREW, 10-24x1/2 BH, BLK OXIDE	2
57	937G	HANDLE	1
59	737F	PAWL	1
60	28	SCREW, DRIVE, #2 x 1/4	1
61	27	SCREW, DRIVE, #8 X 5/8	1
62	937C	STRIP, HANDLE	1
63	737E	NIPPLE, PIPE	1
64	737D	SPRING, BUTTON	1
65	737B-1	BUTTON	1
66	26	PIN, 3/32 x 3/8, ROLL PLTED	1
67	737A	KNOB, REAR TENSION ARM	1
68	3	NUT, 1/4-20 JAM, PLTD	2
69	738	SPRING, BELT TENSION	1
70	939	GUIDE, SPRING	1
71	34	SCREW, 1/4-20 X 1, FH PHILLIPS	1
72	935	SUPPORT, REAR WHEEL	1
74	21	WASHER, 1/2 ID	1
75	20	NUT, NYLOK JAM, 1/2-20	1

**BURR KING**1220 TAMARA LANE  
WARSAW, MO. 65355**NOTE**

\* 011C

ROCKER SWITCH FOR 1PH

# MODEL 960-272

## 10" CONTACT WHEEL

### PARTS LIST

BURR KING

1220 TAMARA LANE  
WARSAW, MO. 65355

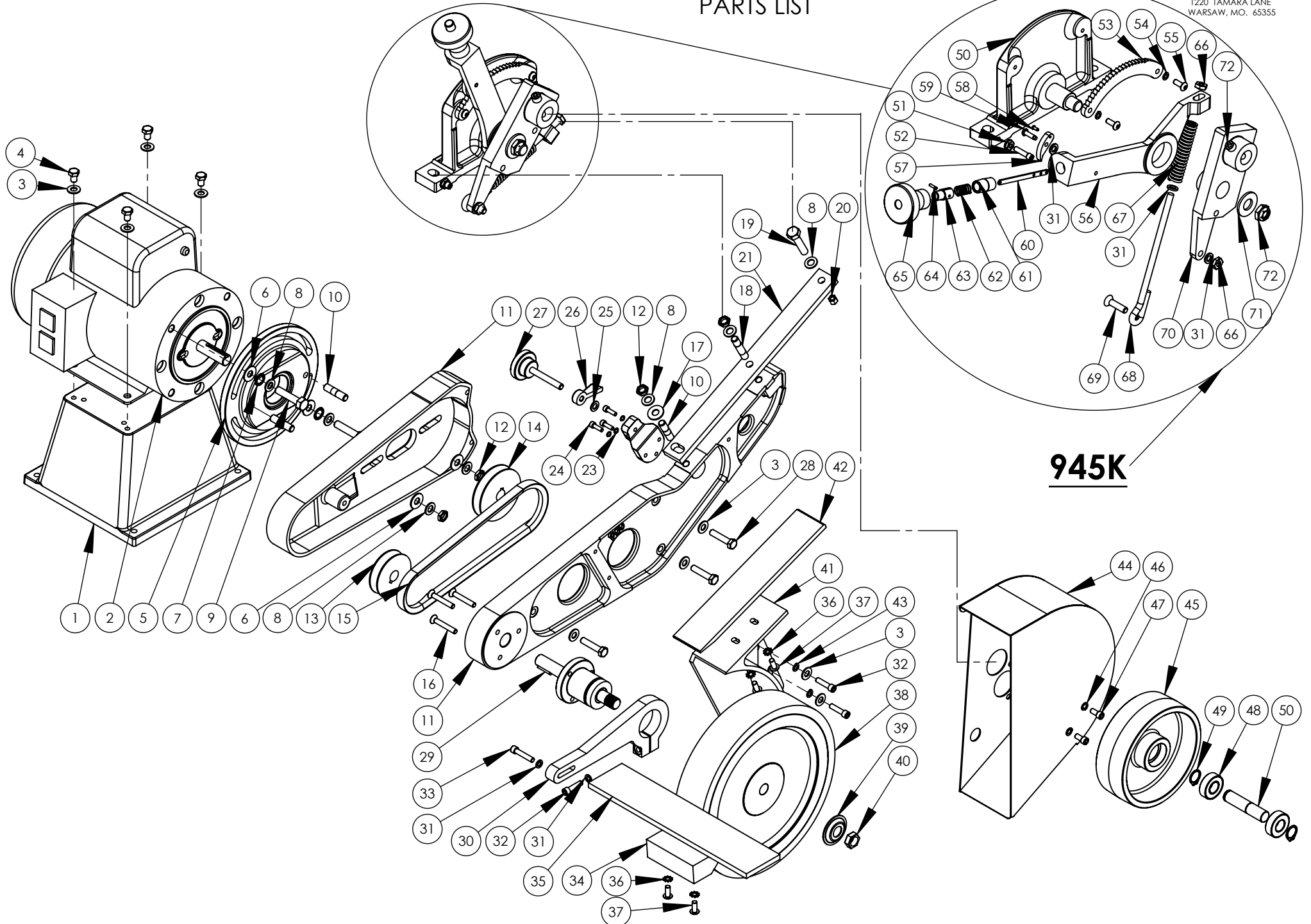

960-272			
ITEM NO.	PART NUMBER	DESCRIPTION	QTY.
1	941	BASE	1
2	MOTOR	CALL FACTORY *	1
3	4	WASHER, 5/16 SAE ZINC PLTD	9
4	2	BOLT, 5/16-18x1 1/2 HEX HEAD	4
5	908	ADAPTER, C-FACE MOTOR	1
6	42	WASHER, SAE, 3/8	4
7	5-0014	WASHER, LOCK 3/8, INTERNAL STAR	2
8	17	WASHER, 960-616, AN	7
9	1-0003	BOLT 3/8-16 x 1 1/4 HEX HEAD	2
10	920	STUD 3/8"x1 1/2", DOUBLE	3
11	900A	FRAME/GUARD ASSEMB	1
12	39	NUT, 3/8-24, JAM, ESNA, NTE	4
13	725	PULLEY, 2 1/2	1
14	730	PULLEY, 3	1
15	429K	BELT, V DRIVE	1
16	6	SCREW 1/4-20 x 1 1/2 FH SOC	3
17	40	WASHER, SAE, 3/8	1
18	920K	STUD 3/8"x1 1/2", DOUBLE	1
19	1-0004	BOLT 3/8-16 x 1 1/4 HEX HEAD	1
20	4-0007	NUT, 3/8-16, ELASTIC LOCK GD 2	1
21	943	BAR, EXTENSION	1
22	923	BRACKET, TRACKING	1
23	5-0035	WASHER, #10, LOCK, HIGH COLLAR	3
24	2-0023	SCREW, 10-24 X .625 ALLEN HEAD	3
25	18	WASHER, 960-516, AN	1
26	922	LOCK, KNOB, TRACKING	1
27	921	KNOB, TRACKING ASSY	1
28	1-0019	BOLT, 5/16-18x1 1/2 HEX HEAD	3
29	701	BEARING, CONTACT WHEEL ASSY	1
30	948K	ARM, WORKREST SUPPORT	1
31	5	WASHER, 1/4 AN	5
32	30	SCREW 1/4-20x1 SHCS	3
33	31	SCREW 1/4-20x1 1/4 SHCS	1
34	706-1M	WORKREST	1
35	966-01	REST EXTENDER	1
36	5-0008	WASHER, 1/4, LOCK, EXTERNAL	4
37	2-0046	SCREW, 1/4-28x1/2 BH, BLK OX	4
38	1002	WHEEL, CONTACT	1
39	726	FLANGE, OUTER WHEEL	1
40	727	NUT, 5/8-18 RH, JAM, BRT PLT	1
41	913	GUARD, 10" DRIVE WHEEL	1
42	964-01	PLATEN, MAIN 272	1

960-272			
ITEM NO.	PART NUMBER	DESCRIPTION	QTY.
43	5-0032	WASHER, 1/4, LOCK, SPLIT, PLTD	4
44	912	GUARD, IDLER WHEEL	1
45	707	IDLER WHEEL 6 X 2, w/BRGS & SHAFT ALUM.	1
46	1431	SCREW, 1/4-20 X 1/2 ALLEN HEAD	2
47	701B	BEARING	2
48	701F	WHEEL, IDLER CIR-CLIP	2
49	707c	SHAFT, BEARING	1

945K			
ITEM NO.	PART NUMBER	DESCRIPTION	QTY.
50	934	SUPPORT, REAR WHL, w/STUD	1
51	14	NUT, 10-24, KEP	1
52	13	SCREW, 10-24 x 3/4, SOC, HD, CAP	1
53	736	SECTOR	1
54	15	WASHER, 5/16 LOCK, SPLIT	2
55	9	SCREW, 10-24x1/2 BH, BLK OXIDE	2
56	937G	HANDLE	1
57	737F	PAWL	1
58	28	SCREW, DRIVE, #2 x 1/4	1
59	27	SCREW, DRIVE, #8 X 5/8	1
60	937C	STRIP, HANDLE	1
61	737E	NIPPLE, PIPE	1
62	737D	SPRING, BUTTON	1
63	737B-1	BUTTON	1
64	26	PIN, 3/32 x 3/8, ROLL PLTD	1
65	737A	KNOB, REAR TENSION ARM	1
66	3	NUT, 1/4-20 JAM, PLTD	2
67	738	SPRING, BELT TENSION	1
68	939	GUIDE, SPRING	1
69	34	SCREW, 1/4-20 X 1, FH PHILLIPS	1
70	935	SUPPORT, REAR WHEEL	1
71	21	WASHER, 1/2 ID	1
72	20	NUT, NYLOK JAM, 1/2-20	1

**NOTE**

\*011C      ROCKER SWITCH 1PH

# MAG STARTER

## PARTS LIST

BURR KING

1220 TAMARA LANE  
WARSAW, MO. 65355

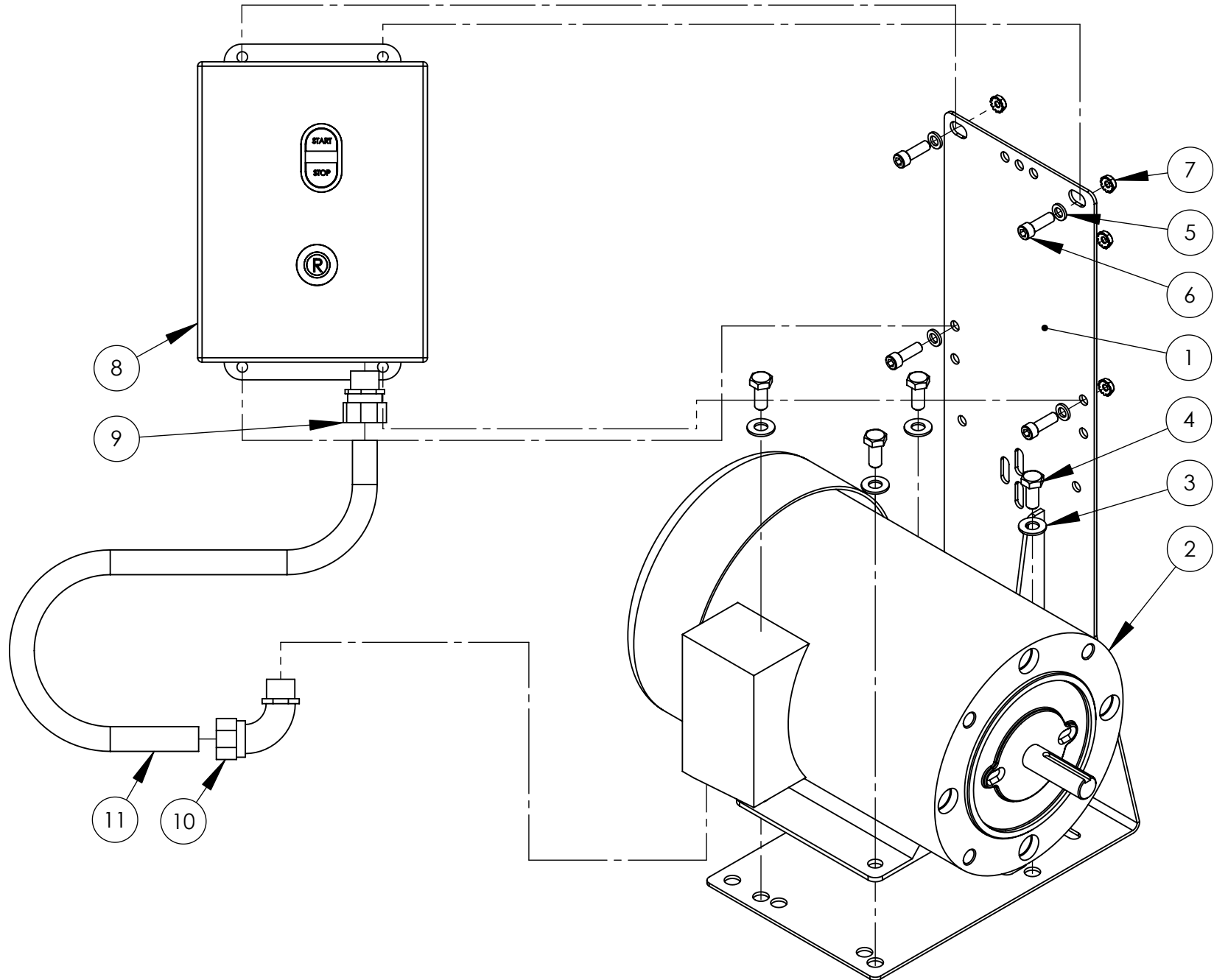

<b>MAG STARTER</b>			
<b>ITEM NO.</b>	<b>PART NUMBER</b>	<b>DESCRIPTION</b>	<b>QTY.</b>
1	MB-4C	BRACKET, MOUNTING, STARTER	1
2	MOTOR	CALL FACTORY FOR PART NUMBER	1
3	4	WASHER, 5/16 SAE ZINC PLTD	4
4	37	BOLT, 5/16-18x3/4 HEX HEAD	4
5	5	WASHER, 1/4 AN	4
6	209	SCREW, 1/4-20 X 3/4 ALLEN HEAD	4
7	4-0013	NUT, KEP, 1/4-20	4
8	MS2A3 MS4A3 MS2B3 MS4B3	3/4HP-1HP, 220V 3/4HP-1HP, 440V 1.5HP-3HP, 220V 1.5HP-3HP, 440V	1
9	775	CONNECTOR, 3/8", STR, LIQ. TIGHT	1
10	776	CONNECTOR, 3/8", 90 DEG, LIQ. TIGHT	1
11	020	CONDUIT 3/8" LIQUID TIGHT	1

# VARI SPEED

SINGLE PHASE



1220 TAMARA LANE  
WARSAW, MO. 65355

**3/4-1 HP**

**1.5-3 HP**

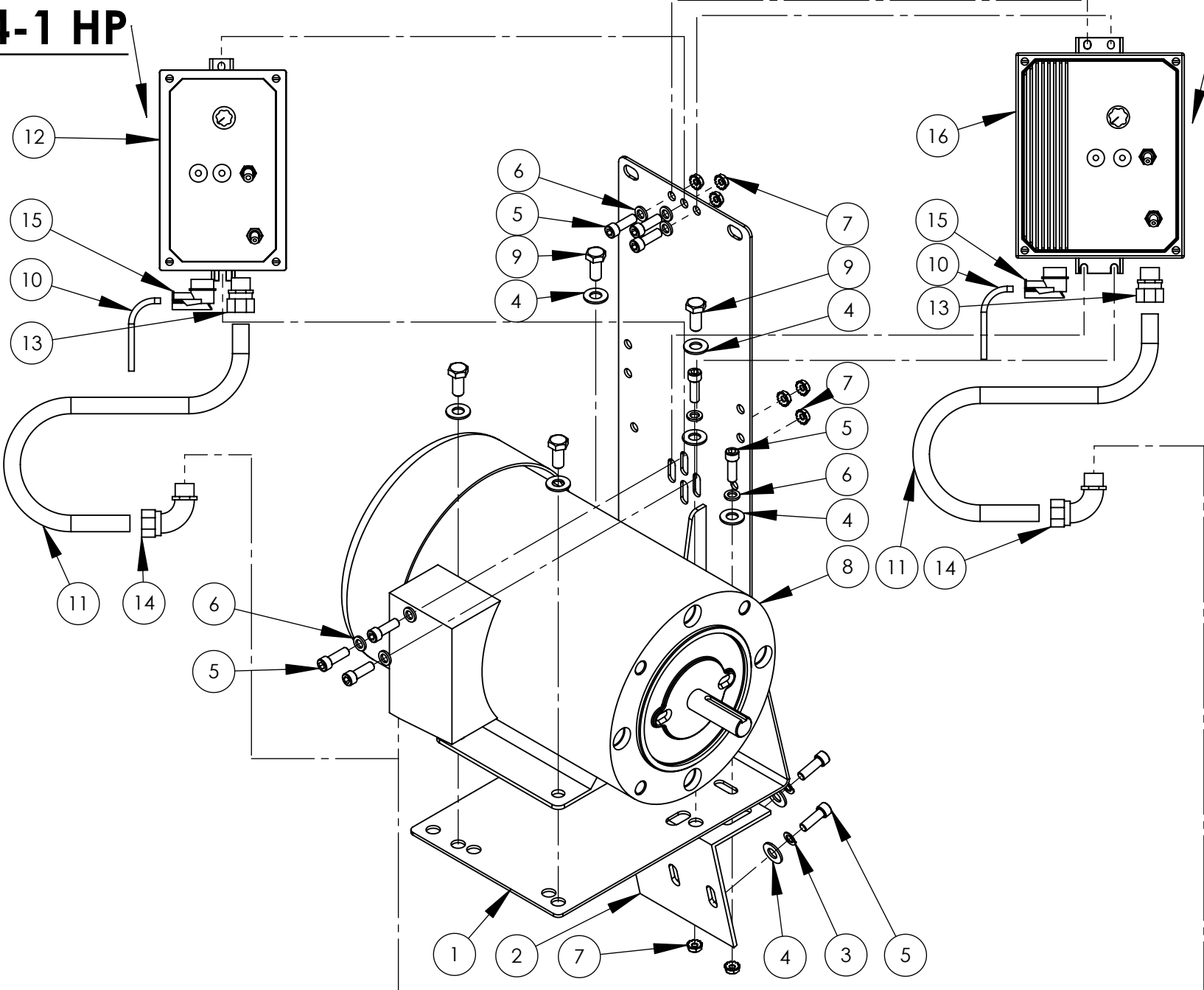

<b>VARI SPEED</b>			
<b>ITEM NO.</b>	<b>PART NUMBER</b>	<b>DESCRIPTION</b>	<b>QTY.</b>
1	MB-4C	BRACKET, MOUNTING, STARTER	1
2	941-3	BRACE, MB4 SUPPORT	1
3	5-0032	WASHER, 1/4, LOCK, SPLIT, PLTD	2
4	4	WASHER, 5/16 SAE ZINC PLTD	8
5	209	SCREW, 1/4-20 X 3/4 ALLEN HEAD	10
6	5	WASHER, 1/4 AN	8
7	4-0013	NUT, KEP, 1/4-20	8
8	100B-1725C 150B-1725C	1 HP MOTOR 1.5 HP MOTOR	1
9	37	BOLT, 5/16-18x3/4 HEX HEAD	4
10	015-1 017	120V CORD 220V CORD	1
11	020	CONDUIT 3/8" LIQUIDTIGHT	1
12	864-1	CONT. 115/220V 0.75-1HP	1
13	775	CONNECTOR, 3/8" STR, LIQ. TIGHT	1
14	776	CONNECTOR, 3/8", 90 DEG, LIQ. TIGHT	1
15	643	RELIEF, STRAIN 3/8" 90 DEG	1
16	862-3	CONT. 115/220V 1.5-3HP	1

**NOTE**

FOR 3 PHASE CONTROLLER CALL FACTORY.

**CE CERTIFICATION PART NUMBERS**

**ADD TO CONTROLLER**

<b>ITEM NO.</b>	<b>PART NUMBER</b>	<b>DESCRIPTION</b>	<b>QTY.</b>
12	9974-6	LINE FILTER	1
16	9974-5	LINE FILTER	1
<b>CHANGE PART</b>			
15	3356	RELIEF, STRAIN	1
10	CE CORD	NO PLUG- CUSTOMER INSTALLED PLUG	1



# OPTIONAL ATTACHMENTS

# 944 PARTS LIST

BURR KING

1220 TAMARA LANE  
WARSAW, MO. 65355

1276

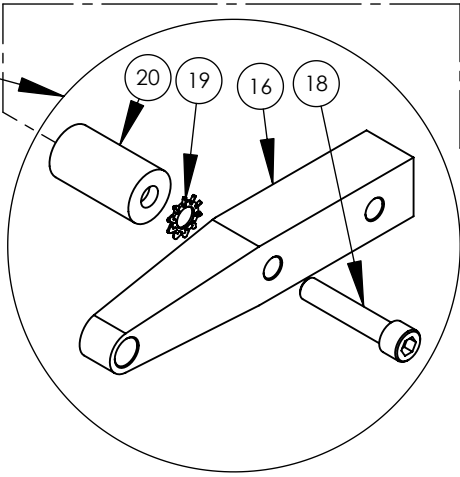

1277

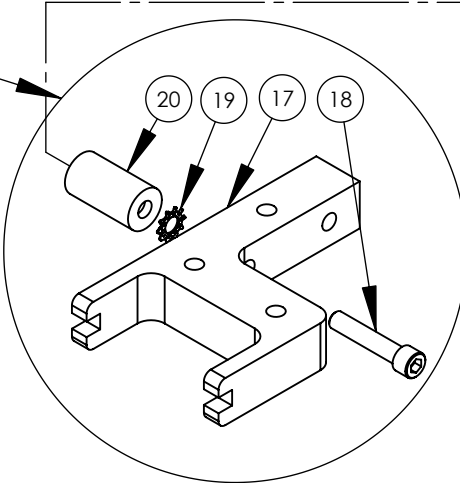

946K

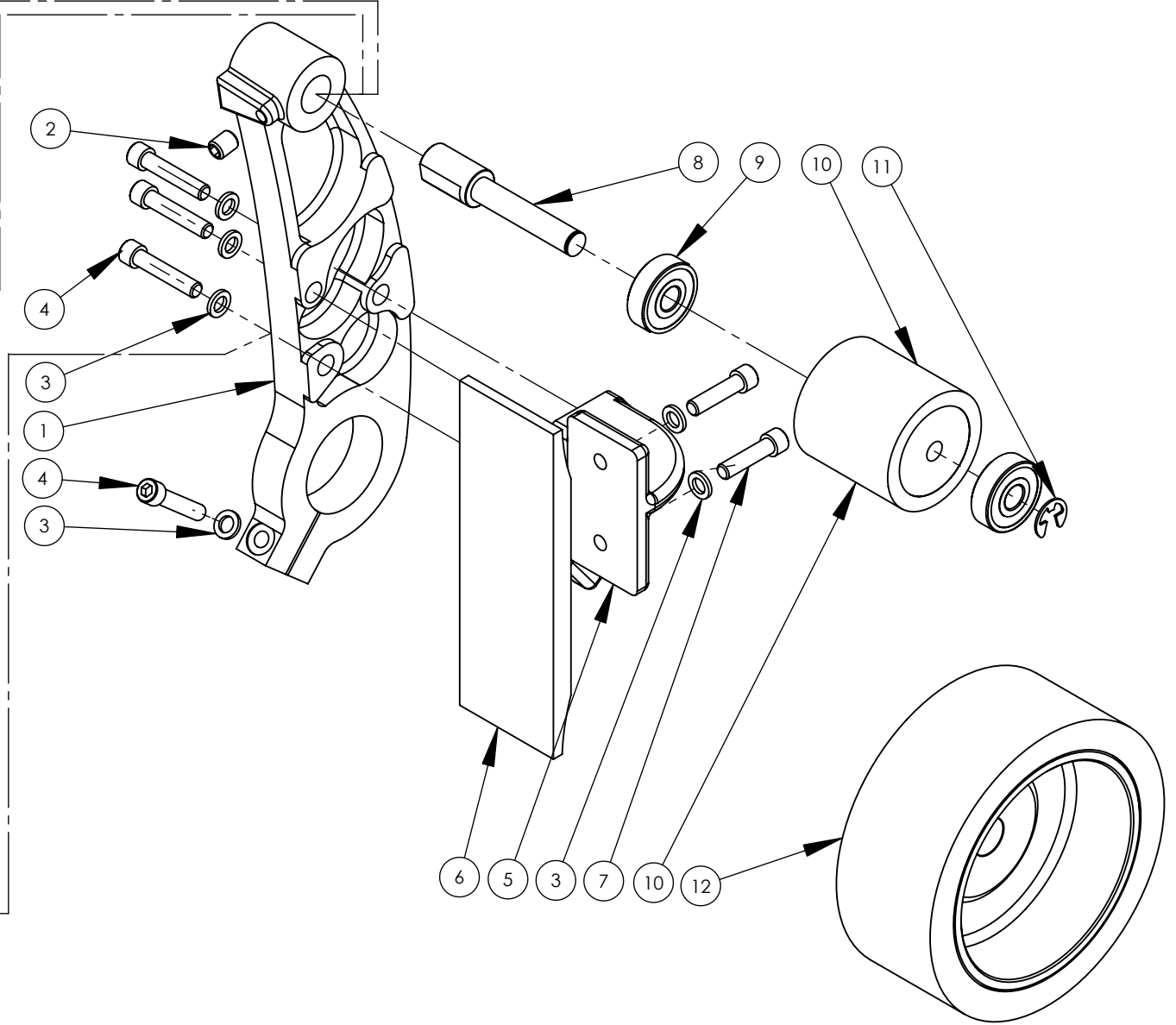
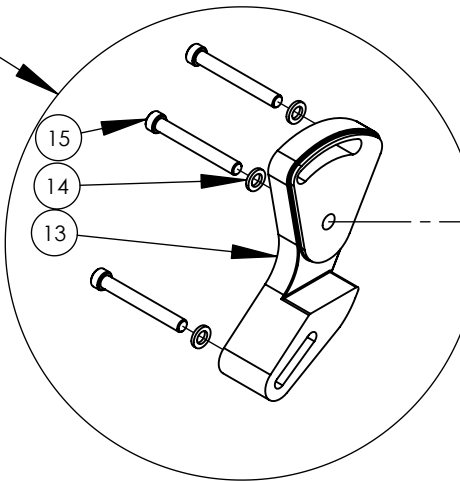

<b>944</b>			
<b>ITEM NO.</b>	<b>PART NUMBER</b>	<b>DESCRIPTION</b>	<b>QTY.</b>
1	9066	ARM, MAIN ATTACHMENT	1
2	25	SCREW, SET, 5/16-18 X 3/8, ALLEN	1
3	5	WASHER, 1/4 AN	6
4	31	SCREW 1/4-20x1 1/4 SHCS	4
5	904B-5	BRACKET, PLATEN	1
6	904AKM	PLATEN	1
7	30	SCREW 1/4-20x1 SHCS	2
8	1444A	SHAFT, IDLER	1
9	202B	BEARING	2
10	202K	WHEEL, CONTACT 2x2 w/Brg. & Shaft	1
11	1454	RING, RETAINING, E STYLE	1
12	402	CONTACT WHL, 5x2	1

**NOTE**

TO USE 944 MUST HAVE 907K IDLER WHEEL.

**OPTIONAL ATTACHMENTS**

<b>946K</b>			
<b>ITEM NO.</b>	<b>PART NUMBER</b>	<b>DESCRIPTION</b>	<b>QTY.</b>
13	946KM	ARM	1
14	5	WASHER, 1/4 AN	3
15	2-0062	SCREW, 1/4-20 X 1.5 ALLEN	3

USE TO ATTACH WORKREST TO 944

<b>1276 &amp; 1277</b>			
<b>ITEM NO.</b>	<b>PART NUMBER</b>	<b>DESCRIPTION</b>	<b>QTY.</b>
16	1276B	ARM, UNI 1x1	1
17	1277B	ARM, FORK 1x2	1
18	31	SCREW 1/4-20x1 1/4 SHCS	2
19	5-0008	WASHER, 1/4, LOCK, EXTERNAL	2
20	1277A	STUD	2

# 965 PARTS LIST

BURR KING

1220 TAMARA LANE  
WARSAW, MO. 65355

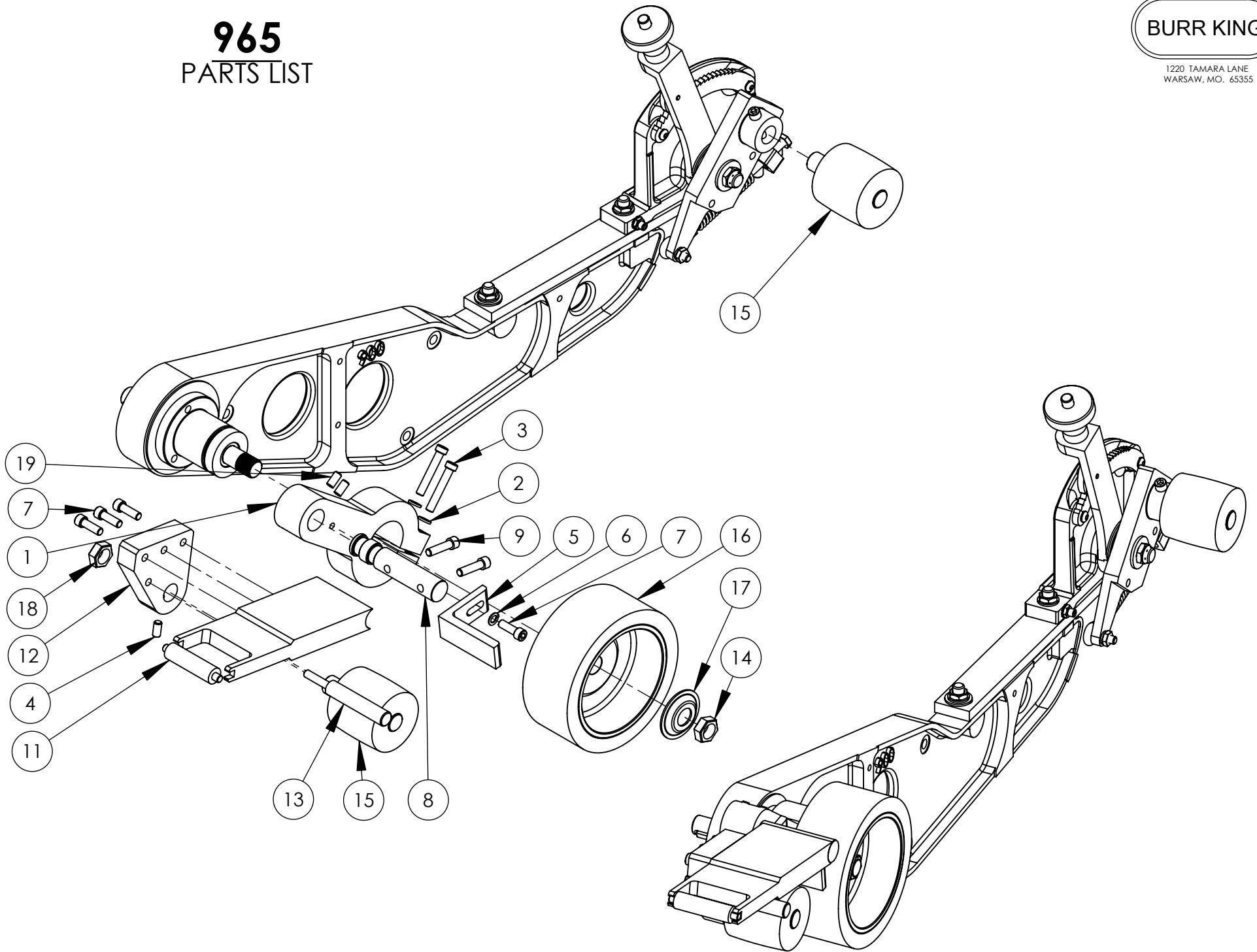

<b>965</b>			
<b>ITEM NO.</b>	<b>PART NUMBER</b>	<b>DESCRIPTION</b>	<b>QTY.</b>
1	1425	BRACKET, MOUNTING	1
2	5	WASHER, 1/4 AN	2
3	2-0011	SCREW, 1/4-20 X 1.5 ALLEN	2
4	1441	SCREW, SET, 1/4-20-1/2, ALLEN	1
5	9653	GUARD, L, SMALL, WHL.	1
6	5-0032	WASHER, 1/4, LOCK, SPLIT, PLTD	1
7	209	SCREW, 1/4-20 X 3/4 ALLEN HEAD	4
8	1426	BAR, PIVOT	1
9	30	1/4-20x1 SHCS	2
10	9654	SUPPORT, ARM, SMALL, WHL.	1
11	*AR2311	CONTACT WHEEL, 1x2, FORK, 70D SM	1
12	9651	SUPPORT, WHEEL, SM	1
13	9652	GUARD, PINCH, SMALL, WHL.	1
14	727	NUT, 5/8-18 RH, JAM, BRT PLT	1
15	1444V	WHEEL, IDLER	2
16	402	CONTACT WHL, 2X5	1
17	726	WASHER, SPRING FLANGE	1
18	4-0015	NUT, 5/8-18 HEX, THIN, NYLON INSERT	1
19	1445	SCREW, 1/4-20x 3/8, SET	2

**\* CALL FACTORY FOR OPTIONAL WHEEL SIZES.**

# MODEL 960-272



1220 TAMARA LANE  
WARSAW, MO. 65355

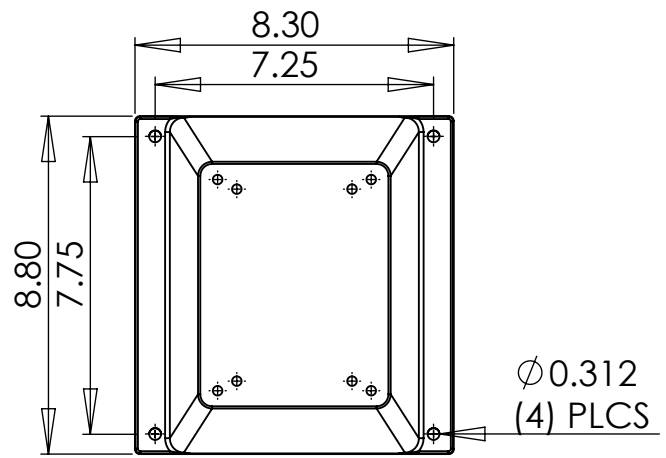

## MOUNTING PATTERN

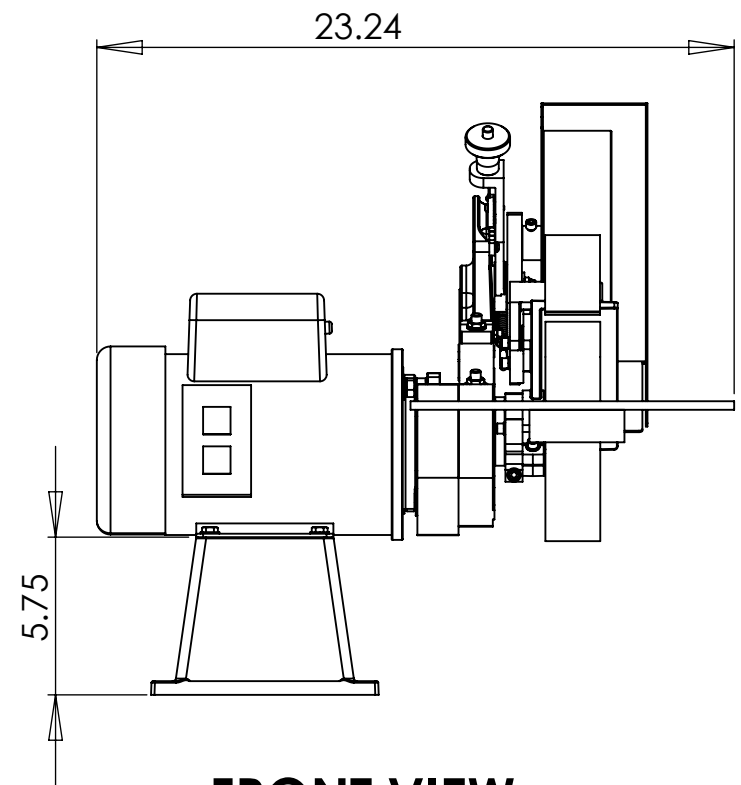

**FRONT VIEW**

FOR 10" WHEEL 37.13  
FOR 8" WHEEL 35.13

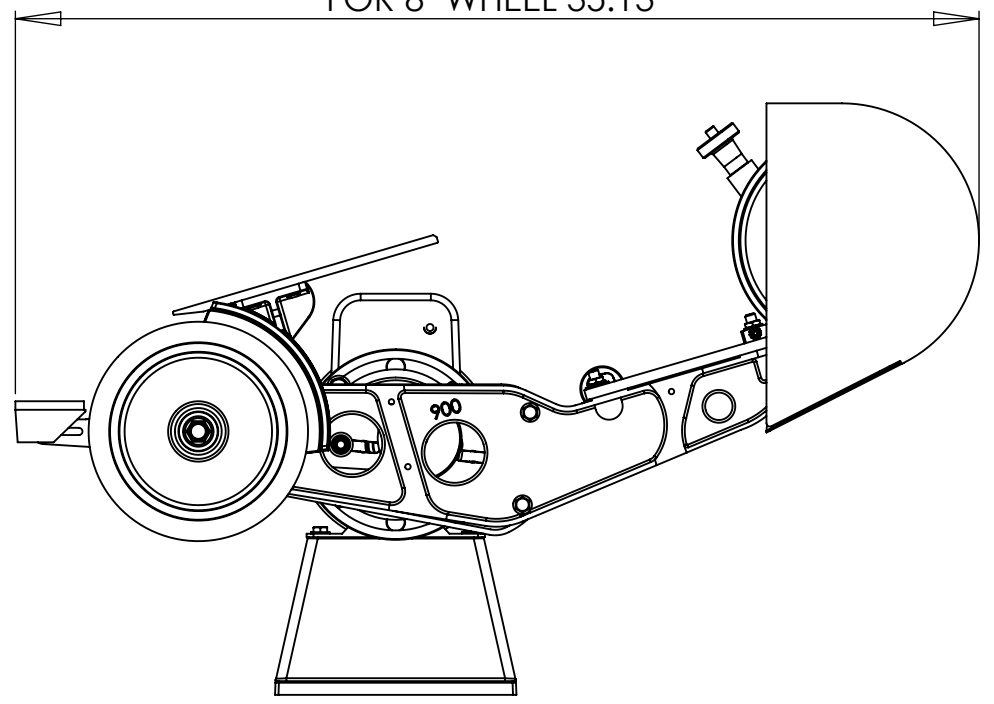

**RIGHT SIDE VIEW**